

(2) 12" FF FLANGE
150 lb ANSI
STANDARD
BOLT PATTERN

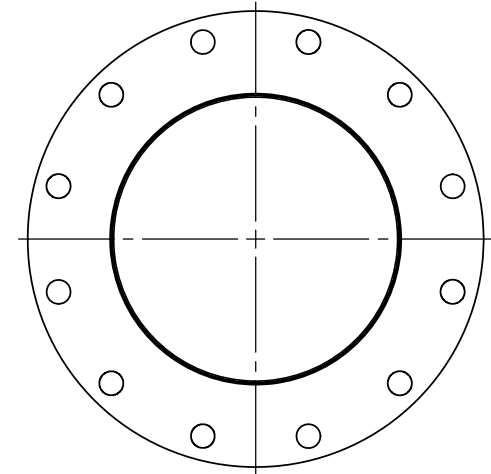
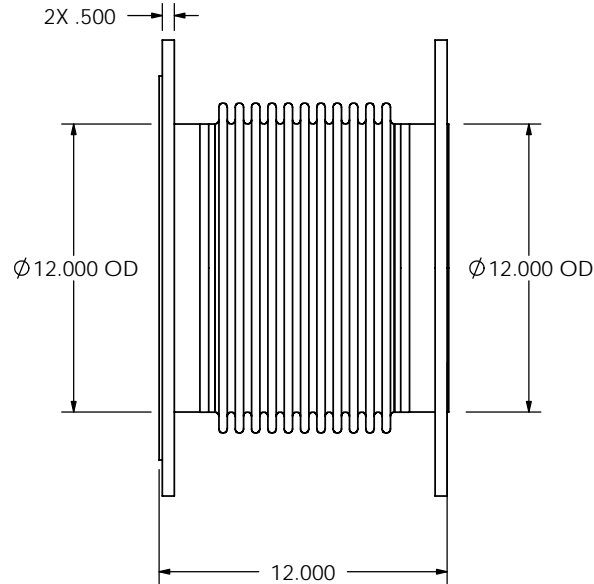
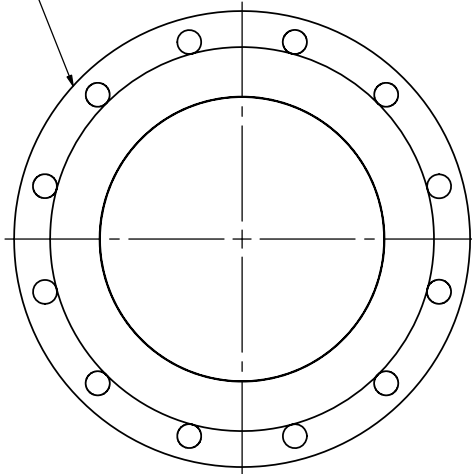

NOTES:

- DO NOT USE EQUIPMENT TO SUPPORT OTHER PARTS OF THE EXHAUST SYSTEM WITHOUT PROPER REINFORCEMENT

MATERIAL CONSTRUCTION:

- CARBON STEEL

PAINT:



- HIGH TEMPERATURE BLACK (MIRATECH COATING SYSTEM 5)

PROJECT NAME	
PROPOSAL NUMBER	
SALES ORDER NO.	
CUSTOMER P.O.	

PROPRIETARY AND CONFIDENTIAL

THE INFORMATION CONTAINED IN THIS DRAWING IS THE SOLE PROPERTY OF MIRATECH GROUP, LLC. ANY REPRODUCTION IN PART OR AS A WHOLE WITHOUT THE WRITTEN PERMISSION OF MIRATECH GROUP, LLC IS PROHIBITED.

DIMENSIONS ARE IN INCHES UNLESS OTHERWISE SPECIFIED	
DIMENSIONAL TOLERANCES UNLESS OTHERWISE SPECIFIED	
ANGLES:	
MACH: ±1*	INCHES: ±0.125
BEND: ±3*	MILLIMETERS: ±2
DO NOT SCALE DRAWING	
DRAWN	DATE
CSF	06/02/2017
REVIEWED BY	DATE
CAC	06/02/2017

 	
BL212-12TF1-12TF2-120-2 Sales Drawing	
DRAWING	REV
BL212-12TF1-12TF2-120-2 SD	0
SIZE	SHEET 1 OF 1
A	
SCALE 1:8	WEIGHT: 52 lb