

6" FF FLANGE  
150 lb ANSI  
STANDARD  
BOLT PATTERN

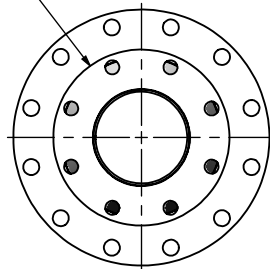

10" FF FLANGE  
150 lb ANSI  
STANDARD  
BOLT PATTERN

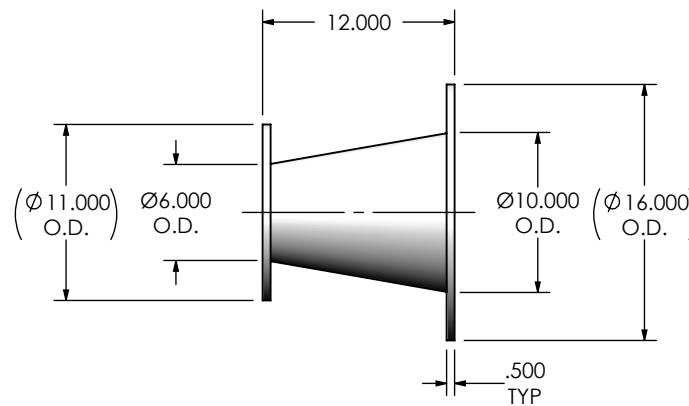
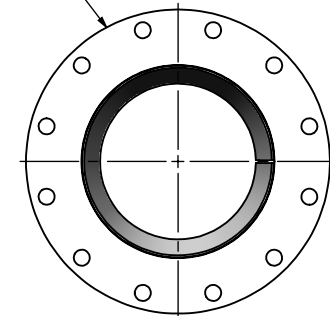

**NOTES:**

- DO NOT USE EQUIPMENT TO SUPPORT OTHER PARTS OF THE EXHAUST SYSTEM WITHOUT PROPER REINFORCEMENT

**MATERIAL CONSTRUCTION:**

- CARBON STEEL

**PAINT:**

- HIGH TEMPERATURE BLACK (MIRATECH COATING SYSTEM 5)

PROJECT NAME	<p><b>PROPRIETARY AND CONFIDENTIAL</b></p> <p>THE INFORMATION CONTAINED IN THIS DRAWING IS THE SOLE PROPERTY OF MIRATECH GROUP, LLC. ANY REPRODUCTION IN PART OR AS A WHOLE WITHOUT THE WRITTEN PERMISSION OF MIRATECH GROUP, LLC IS PROHIBITED.</p>	<p>DIMENSIONS ARE IN INCHES UNLESS OTHERWISE SPECIFIED</p>				
PROPOSAL NUMBER		<p><small>DIMENSIONAL TOLERANCES UNLESS OTHERWISE SPECIFIED</small></p> <p>ANGLES:                      INCHES:                      ±0.125</p> <p>MACH: ±1"                      BEND: ±3"                      MILLIMETERS:                      ±2</p>				
SALES ORDER NO.		<p>DO NOT SCALE DRAWING</p>		<p><b>CN-06TF1-10TF1-120-2</b></p> <p><b>Sales Drawing</b></p>		
CUSTOMER P.O.		<p>DRAWN: CAC</p> <p>DATE: 06/2/2017</p>	<p>REVIEWED BY: AJM</p> <p>DATE: 6/2/2017</p>			