

(2) 18" FF FLANGE  
150 lb ANSI  
STANDARD  
BOLT PATTERN

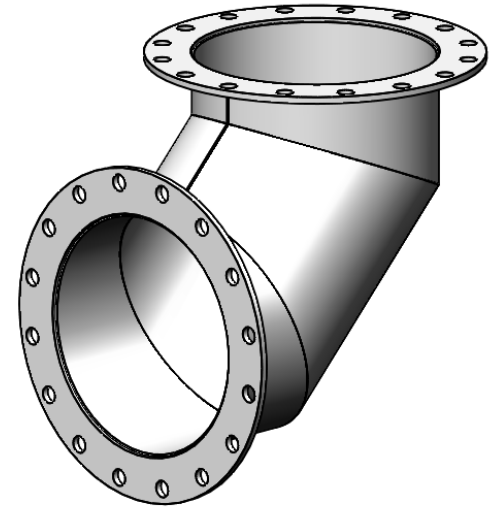
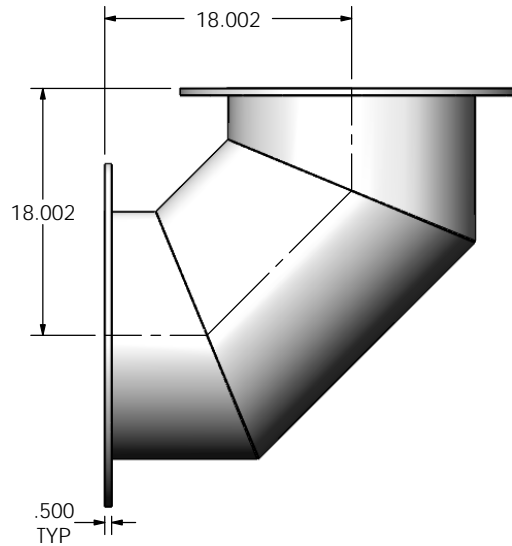

**NOTES:**

- DO NOT USE EQUIPMENT TO SUPPORT OTHER PARTS OF THE EXHAUST SYSTEM WITHOUT PROPER REINFORCEMENT

**MATERIAL CONSTRUCTION:**

- CARBON STEEL

**PAINT:**



- HIGH TEMPERATURE BLACK (MIRATECH COATING SYSTEM 5)

PROJECT NAME
PROPOSAL NUMBER
SALES ORDER NO.
CUSTOMER P.O.

**PROPRIETARY AND CONFIDENTIAL**

THE INFORMATION CONTAINED IN THIS DRAWING IS THE SOLE PROPERTY OF MIRATECH GROUP, LLC. ANY REPRODUCTION IN PART OR AS A WHOLE WITHOUT THE WRITTEN PERMISSION OF MIRATECH GROUP, LLC IS PROHIBITED.

DIMENSIONS ARE IN INCHES UNLESS OTHERWISE SPECIFIED	
DIMENSIONAL TOLERANCES UNLESS OTHERWISE SPECIFIED	
ANGLES:	
MACH: ±1*	INCHES: ±0.125
BEND: ±3*	MILLIMETERS: ±2
DO NOT SCALE DRAWING	
DRAWN	DATE
CSF	11/28/2016
REVIEWED BY	DATE
AJM	11/28/2016

 	
<b>EL-18PF1-18PF1-180X0180-2 SD</b> <b>Sales Drawing</b>	
DRAWING	REV
EL-18PF1-18PF1-180X0180-2 SD	0
SIZE	SHEET 1 OF 1
A	
SCALE 1:14	WEIGHT: 122 lb