

REVISIONS				
REV.	DESCRIPTION	DATE	SHEET(S)	DRAWN BY
0	ORIGINAL RELEASE	08/08/2016	-	JFS
1	UPDATE DRAIN PLUG DESCRIPTION	11/1/2017	-	CSF
2	CORRECTED CONNECTION NOTE	10/22/2018	-	CAC

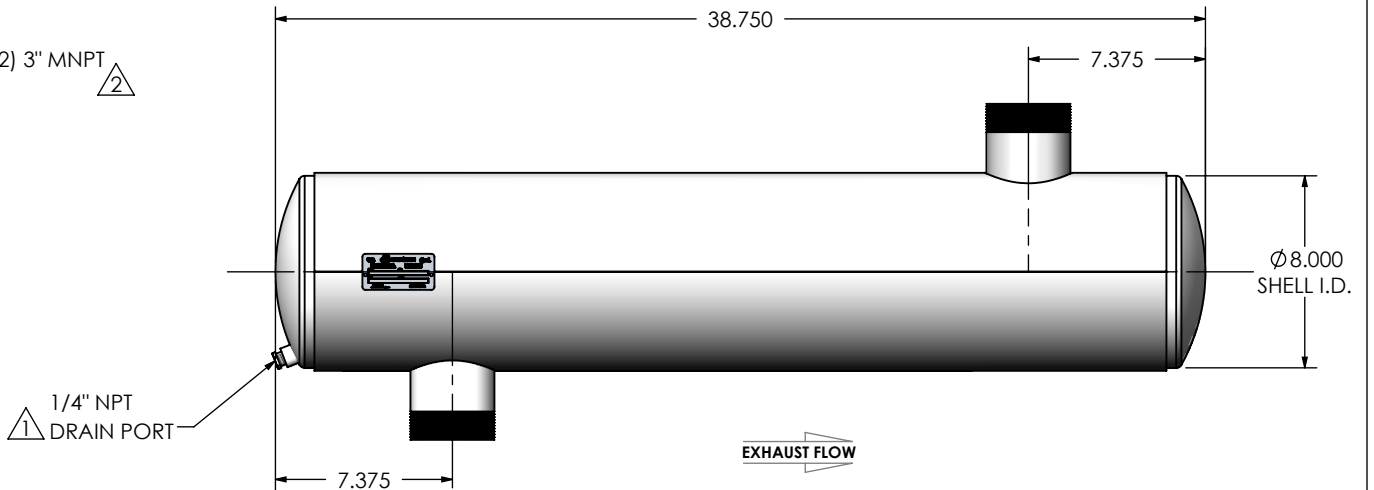
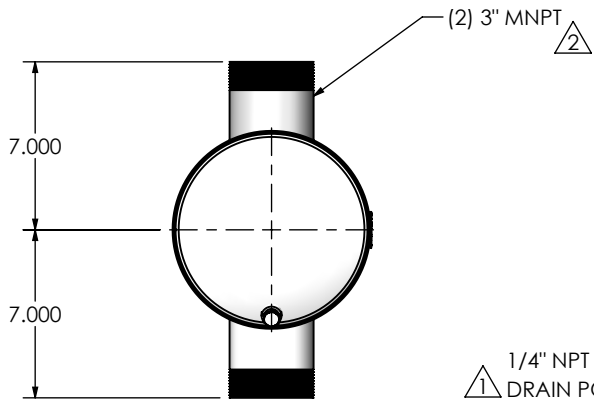
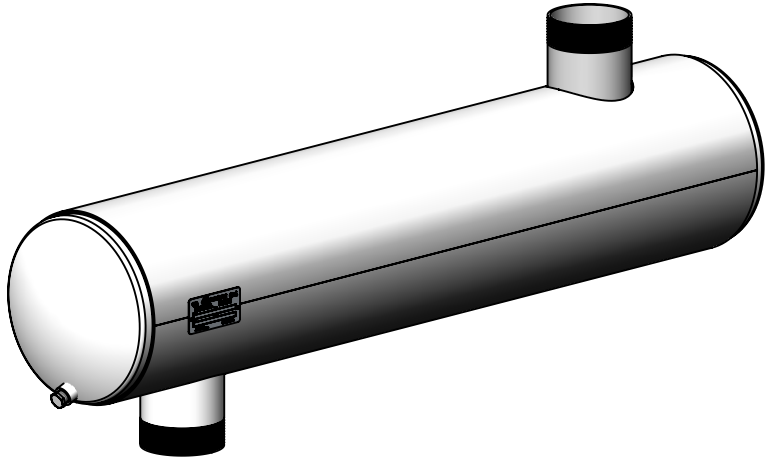

NOTES:

- DO NOT USE EQUIPMENT TO SUPPORT OTHER PARTS OF THE EXHAUST SYSTEM WITHOUT PROPER REINFORCEMENT

MATERIAL CONSTRUCTION:

- ALUMINIZED STEEL

PAINT:

- HIGH TEMPERATURE BLACK (MIRATECH COATING SYSTEM 5)

PROJECT NAME	PROPRIETARY AND CONFIDENTIAL THE INFORMATION CONTAINED IN THIS DRAWING IS THE SOLE PROPERTY OF MIRATECH GROUP, LLC. ANY REPRODUCTION IN PART OR AS A WHOLE WITHOUT THE WRITTEN PERMISSION OF MIRATECH GROUP, LLC IS PROHIBITED.
PROPOSAL NUMBER	
SALES ORDER NO.	
CUSTOMER P.O.	

PROPRIETARY AND CONFIDENTIAL

THE INFORMATION CONTAINED IN THIS DRAWING IS THE SOLE PROPERTY OF MIRATECH GROUP, LLC. ANY REPRODUCTION IN PART OR AS A WHOLE WITHOUT THE WRITTEN PERMISSION OF MIRATECH GROUP, LLC IS PROHIBITED.

DIMENSIONS ARE IN INCHES UNLESS OTHERWISE SPECIFIED	
DIMENSIONAL TOLERANCES UNLESS OTHERWISE SPECIFIED	
ANGLES:	
MACH: \pm 1"	INCHES: \pm 0.125
BEND: \pm 3"	MILLIMETERS: \pm 2
DO NOT SCALE DRAWING	
DRAWN	DATE
JFS	08/08/2016
REVIEWED BY	DATE
EQJ	08/19/2016

JCGA0-03MN-1-00001RX5 Sales Drawing			
DRAWING		REV	
JCGA0-03MN-1-00001RX5 SD		2	
SIZE	SCALE 1:8	WEIGHT: 46 lb	SHEET 1 OF 1
A			