

REVISIONS				
REV.	DESCRIPTION	DATE	SHEET(S)	DRAWN BY
0	ORIGINAL RELEASE	08/08/2016	-	JFS
1	UPDATE DRAIN PLUG DESCRIPTION	11/2/2017	-	CSF
2	CORRECTED OAL FROM 38" TO 38-1/2"	11/29/2018	-	CAC
3	UPDATED MNPT NOTATION	01/04/2018	-	JFH

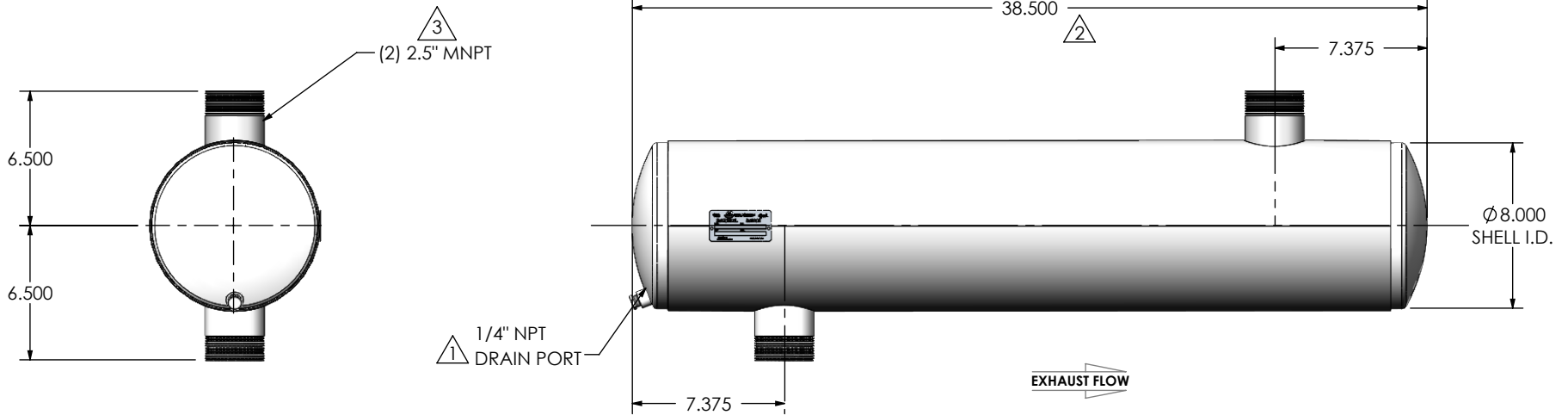
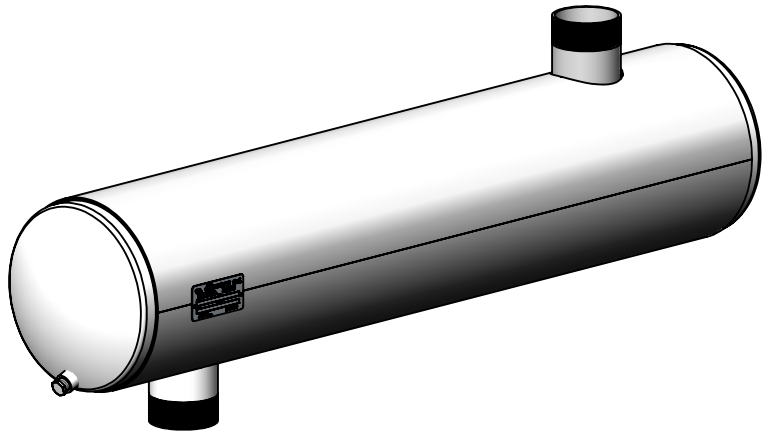

NOTES:

- DO NOT USE EQUIPMENT TO SUPPORT OTHER PARTS OF THE EXHAUST SYSTEM WITHOUT PROPER REINFORCEMENT

MATERIAL CONSTRUCTION:

- CARBON STEEL

PAINT:

- HIGH TEMPERATURE BLACK (MIRATECH COATING SYSTEM 5)

PROJECT NAME	PROPRIETARY AND CONFIDENTIAL THE INFORMATION CONTAINED IN THIS DRAWING IS THE SOLE PROPERTY OF MIRATECH GROUP, LLC. ANY REPRODUCTION IN PART OR AS A WHOLE WITHOUT THE WRITTEN PERMISSION OF MIRATECH GROUP, LLC IS PROHIBITED.	DIMENSIONS ARE IN INCHES UNLESS OTHERWISE SPECIFIED		
PROPOSAL NUMBER		<small>DIMENSIONAL TOLERANCES UNLESS OTHERWISE SPECIFIED</small> ANGLES: MACH: $\pm 1^\circ$ INCHES: ± 0.125 BEND: $\pm 3^\circ$ MILLIMETERS: ± 2		
SALES ORDER NO.		DO NOT SCALE DRAWING		JCGA0-25MN-2-00001RX5 Sales Drawing
CUSTOMER P.O.		DRAWN: JFS	DATE: 08/08/2016	
		REVIEWED BY: EQJ	DATE: 08/19/2016	SIZE: A SCALE: 1:8 WEIGHT: 42 lb SHEET 1 OF 1