

REVISIONS				
REV.	DESCRIPTION	DATE	SHEET(S)	DRAWN BY
0	ORIGINAL RELEASE	08/08/2016	-	JFS
1	UPDATE DRAIN PLUG DESCRIPTION	11/2/2017	-	CSF
2	CORRETED OAL FROM 38" TO 38-1/2"	11/29/2018	-	CAC
3	UPDATED MNPT NOTATION	01/04/2018	-	JFH

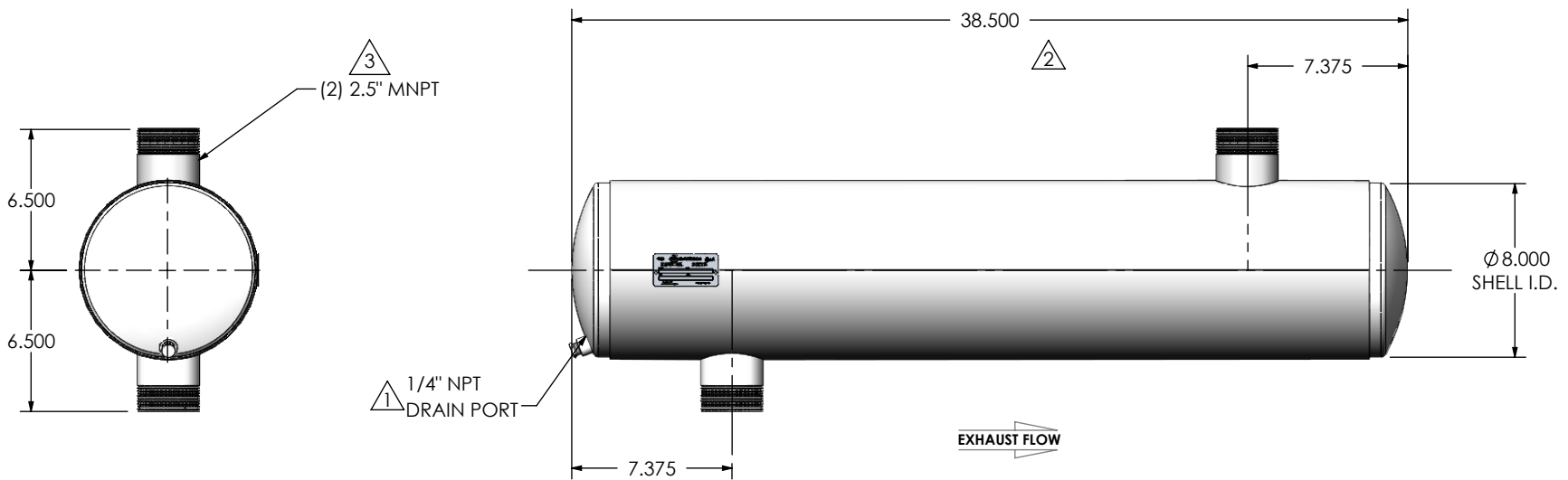
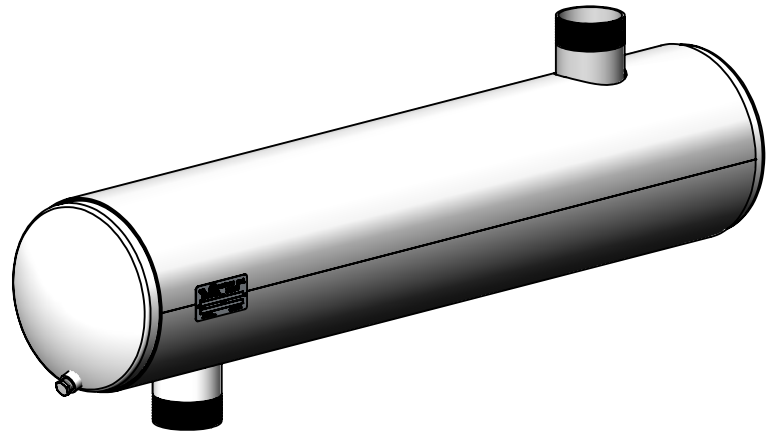

NOTES:

- DO NOT USE EQUIPMENT TO SUPPORT OTHER PARTS OF THE EXHAUST SYSTEM WITHOUT PROPER REINFORCEMENT

MATERIAL CONSTRUCTION:

- 304 STAINLESS STEEL

PAINT:

- NONE

PROJECT NAME	PROPRIETARY AND CONFIDENTIAL THE INFORMATION CONTAINED IN THIS DRAWING IS THE SOLE PROPERTY OF MIRATECH GROUP, LLC. ANY REPRODUCTION IN PART OR AS A WHOLE WITHOUT THE WRITTEN PERMISSION OF MIRATECH GROUP, LLC IS PROHIBITED.	DIMENSIONS ARE IN INCHES UNLESS OTHERWISE SPECIFIED <small> DIMENSIONAL TOLERANCES UNLESS OTHERWISE SPECIFIED ANGLES: MACH: ±1° INCHES: ±0.125 BEND: ±3° MILLIMETERS: ±2 </small>				
PROPOSAL NUMBER		DO NOT SCALE DRAWING		JCGA0-25MN-3-00001RX5 Sales Drawing		
SALES ORDER NO.		DRAWN	DATE	DRAWING		
CUSTOMER P.O.		JFS	08/08/2016	JCGA0-25MN-3-00001RX5 SD		
	REVIEWED BY	DATE	SIZE	SCALE	WEIGHT	
	EQJ	08/19/2016	A	1:8	44 lb	
					SHEET 1 OF 1	