

REVISIONS				
REV.	DESCRIPTION	DATE	SHEET(S)	DRAWN BY
1	CORRECTED PART NUMBER IN TITLE BLOCK	6/21/2017	1	CAC

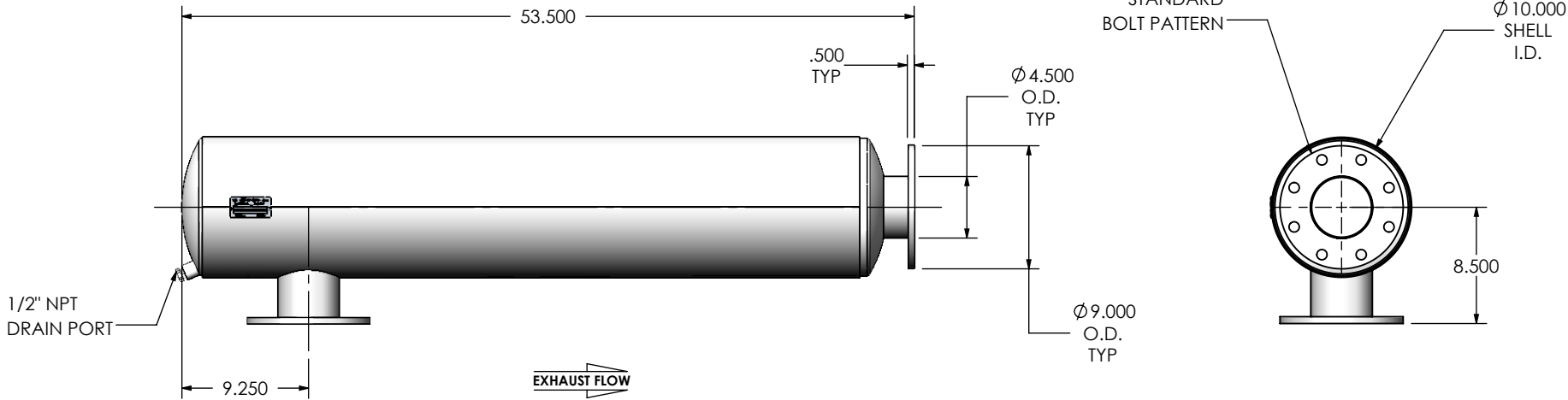
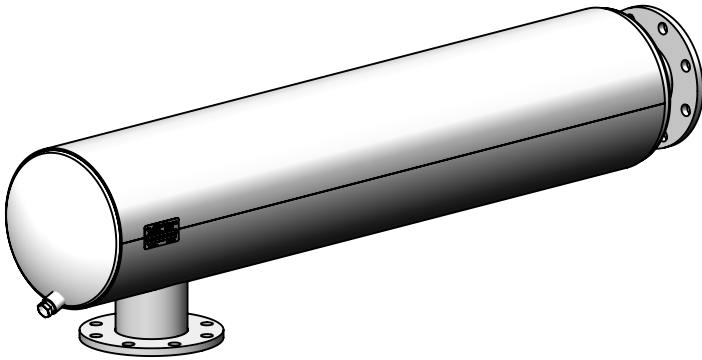

NOTES:

- DO NOT USE EQUIPMENT TO SUPPORT OTHER PARTS OF THE EXHAUST SYSTEM WITHOUT PROPER REINFORCEMENT

MATERIAL CONSTRUCTION:

- 304 STAINLESS STEEL

PAINT:

- NONE

PROJECT NAME	<p>PROPRIETARY AND CONFIDENTIAL</p> <p>THE INFORMATION CONTAINED IN THIS DRAWING IS THE SOLE PROPERTY OF MIRATECH GROUP, LLC. ANY REPRODUCTION IN PART OR AS A WHOLE WITHOUT THE WRITTEN PERMISSION OF MIRATECH GROUP, LLC IS PROHIBITED.</p>
PROPOSAL NUMBER	
SALES ORDER NO.	
CUSTOMER P.O.	

<p>DIMENSIONS ARE IN INCHES UNLESS OTHERWISE SPECIFIED</p> <p>ANGLES: MACH: ±1° INCHES: ±0.125 BEND: ±3° MILLIMETERS: ±2</p> <p>DO NOT SCALE DRAWING</p>	
DRAWN	DATE
JFS	08/08/2016
REVIEWED BY	DATE
EQJ	08/19/2016

<p>DRAWING</p> <p>JCGE0-04PF-3-0000002N SD</p>	
SIZE	SCALE 1:12
A	WEIGHT: 89 lb

<p>JCGE0-04PF-3-0000002N</p> <p>Sales Drawing</p>	
<p>WARNING</p>	
<p>DRAWING</p> <p>JCGE0-04PF-3-0000002N SD</p>	
REV	SHEET 1 OF 1
1	1