

| REVISIONS | | | | |
|-----------|-------------------------------|------------|----------|----------|
| REV. | DESCRIPTION | DATE | SHEET(S) | DRAWN BY |
| 0 | ORIGINAL RELEASE | 08/08/2016 | - | JFS |
| 1 | UPDATE DRAIN PLUG DESCRIPTION | 11/2/2017 | - | CSF |
| 2 | UPDATED MNPT NOTATION | 01/04/2018 | - | JFH |

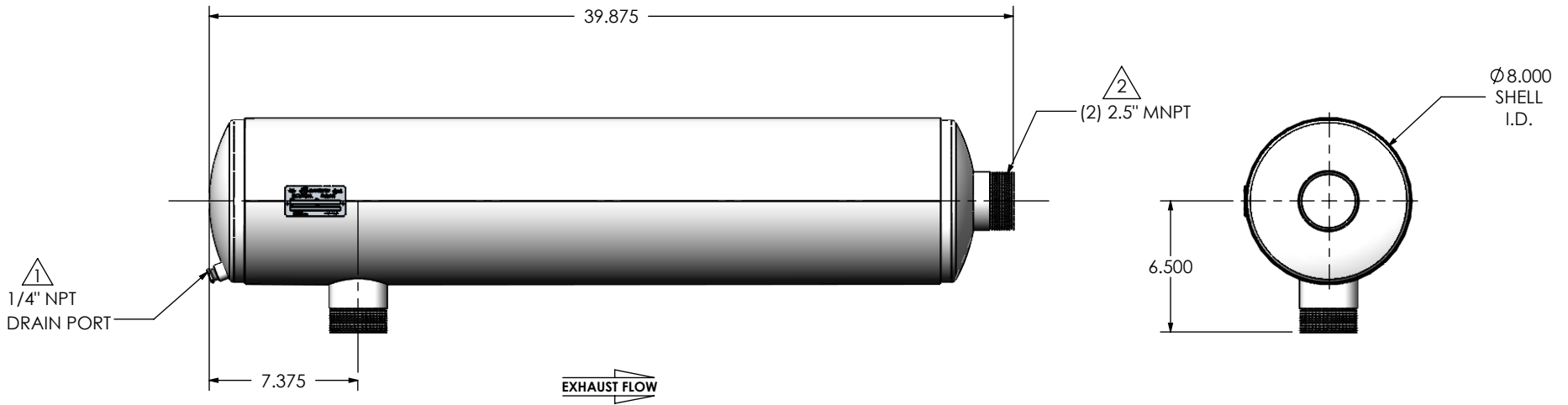

NOTES:

- DO NOT USE EQUIPMENT TO SUPPORT OTHER PARTS OF THE EXHAUST SYSTEM WITHOUT PROPER REINFORCEMENT

MATERIAL CONSTRUCTION:

- CARBON STEEL

PAINT:

- HIGH TEMPERATURE BLACK (MIRATECH COATING SYSTEM 5)

| | |
|-----------------|---|
| PROJECT NAME | PROPRIETARY AND CONFIDENTIAL THE INFORMATION CONTAINED IN THIS DRAWING IS THE SOLE PROPERTY OF MIRATECH GROUP, LLC. ANY REPRODUCTION IN PART OR AS A WHOLE WITHOUT THE WRITTEN PERMISSION OF MIRATECH GROUP, LLC IS PROHIBITED. |
| PROPOSAL NUMBER | |
| SALES ORDER NO. | |
| CUSTOMER P.O. | |

| | |
|---|-----------------|
| DIMENSIONS ARE IN INCHES UNLESS OTHERWISE SPECIFIED | |
| DIMENSIONAL TOLERANCES UNLESS OTHERWISE SPECIFIED | |
| ANGLES: | |
| MACH: ±1° | INCHES: ±0.125 |
| BEND: ±3° | MILLIMETERS: ±2 |
| DO NOT SCALE DRAWING | |
| DRAWN | DATE |
| JFS | 08/08/2016 |
| REVIEWED BY | DATE |
| EQJ | 08/19/2016 |

| | | | |
|--|---|--------------------------|-------|
| | | | |
| JCGE0-25MN-2-00000024 Sales Drawing | | | |
| DRAWING | | JCGE0-25MN-2-00000024 SD | |
| REV | 2 | SIZE | A |
| | | SCALE | 1:8 |
| | | WEIGHT | 42 lb |
| | | SHEET 1 OF 1 | |