

REVISIONS				
REV.	DESCRIPTION	DATE	SHEET(S)	DRAWN BY
0	RELEASED FOR CUSTOMER APPROVAL	11/2/2016	-	FES
1	UPDATED DRAIN PLUG DESCRIPTION	11/3/2017	1	SSC

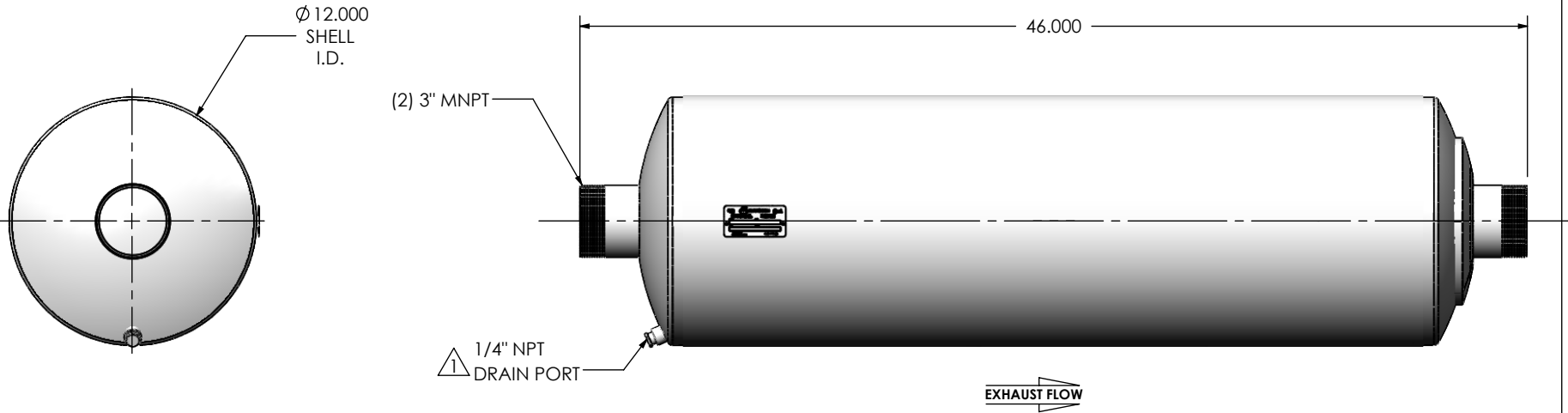
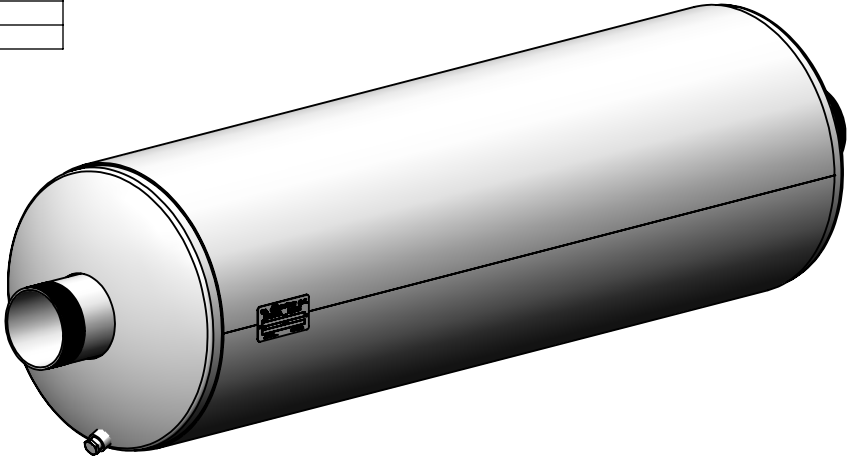

**NOTES:**

- DO NOT USE EQUIPMENT TO SUPPORT OTHER PARTS OF THE EXHAUST SYSTEM WITHOUT PROPER REINFORCEMENT

**MATERIAL CONSTRUCTION:**

- 304 STAINLESS STEEL

**PAINT:**

- NONE

PROJECT NAME	<b>PROPRIETARY AND CONFIDENTIAL</b>  THE INFORMATION CONTAINED IN THIS DRAWING IS THE SOLE PROPERTY OF MIRATECH GROUP, LLC. ANY REPRODUCTION IN PART OR AS A WHOLE WITHOUT THE WRITTEN PERMISSION OF MIRATECH GROUP, LLC IS PROHIBITED.	DIMENSIONS ARE IN INCHES UNLESS OTHERWISE SPECIFIED			<b>JHEE0-03MN-3-00000000</b> <b>Sales Drawing</b>	
PROPOSAL NUMBER		<small>DIMENSIONAL TOLERANCES UNLESS OTHERWISE SPECIFIED</small> ANGLES: MACH: ±1° INCHES: ±0.125 BEND: ±3° MILLIMETERS: ±2				
SALES ORDER NO.		DO NOT SCALE DRAWING		DRAWING		
CUSTOMER P.O.		DRAWN: FES REVIEWED BY: AJM	DATE: 11/2/2016 DATE: 11/4/2016	JHEE0-03MN-3-00000000 SD SIZE: A SCALE: 1:8 WEIGHT: 0 lb	REV: 1 SHEET 1 OF 1	