

(2) 18" FF FLANGE
150 lb ANSI
STANDARD
BOLT PATTERN

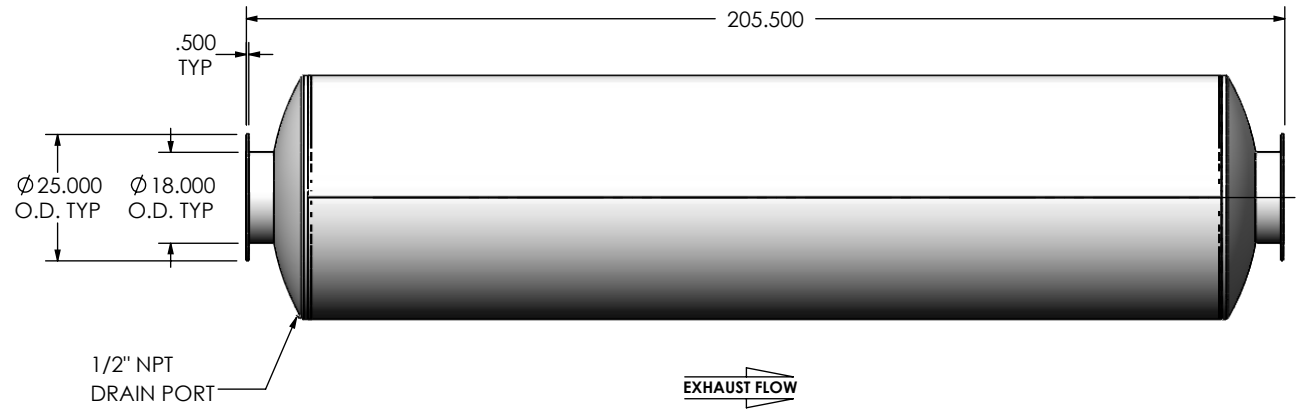

NOTES:

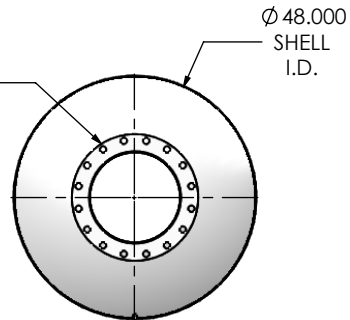

- DO NOT USE EQUIPMENT TO SUPPORT OTHER PARTS OF THE EXHAUST SYSTEM WITHOUT PROPER REINFORCEMENT

MATERIAL CONSTRUCTION:

- 304 STAINLESS STEEL

PAINT:

- NONE

PROJECT NAME	PROPRIETARY AND CONFIDENTIAL THE INFORMATION CONTAINED IN THIS DRAWING IS THE SOLE PROPERTY OF MIRATECH GROUP, LLC. ANY REPRODUCTION IN PART OR AS A WHOLE WITHOUT THE WRITTEN PERMISSION OF MIRATECH GROUP, LLC IS PROHIBITED.	DIMENSIONS ARE IN INCHES UNLESS OTHERWISE SPECIFIED <small>ANGLES</small> MACH: ±1° INCHES: ±0.125 BEND: ±3° MILLIMETERS: ±2		 		
PROPOSAL NUMBER		DO NOT SCALE DRAWING		JHEE0-18PF-3-00000000 Sales Drawing		
SALES ORDER NO.		DRAWN	DATE	DRAWING		
CUSTOMER P.O.		FES	10/26/2016	JHEE0-18PF-3-00000000 SD		
	REVIEWED BY	DATE	SIZE	SCALE	WEIGHT	REV
	AJM	10/31/2016	A	1:38	1809 lb	0
						SHEET 1 OF 1