

REVISIONS				
REV.	DESCRIPTION	DATE	SHEET(S)	DRAWN BY
0	RELEASED FOR CUSTOMER APPROVAL	11/2/2016	-	FES
1	UPDATED DRAIN PLUG DESCRIPTION	11/3/2017	1	SSC

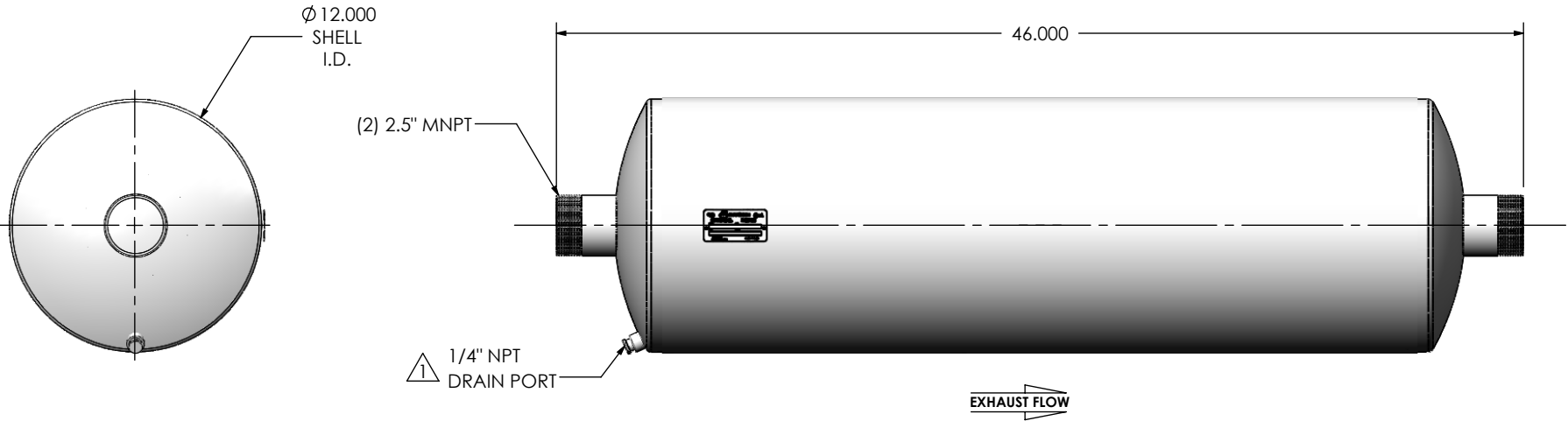
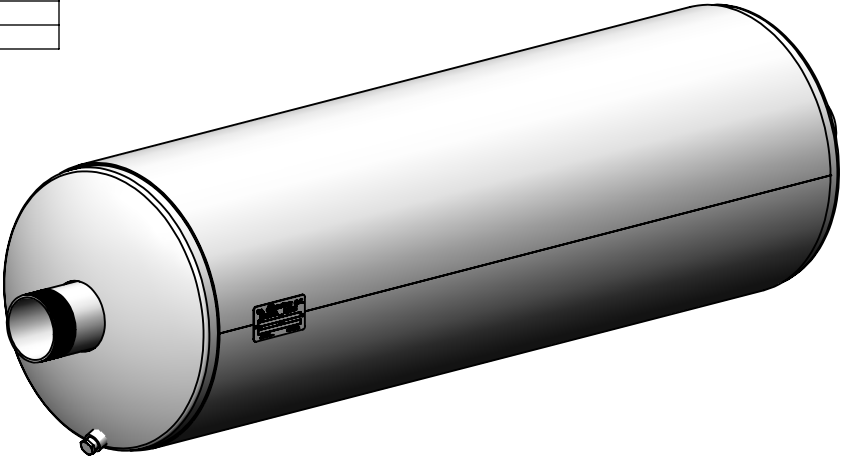

**NOTES:**

- DO NOT USE EQUIPMENT TO SUPPORT OTHER PARTS OF THE EXHAUST SYSTEM WITHOUT PROPER REINFORCEMENT

**MATERIAL CONSTRUCTION:**

- 304 STAINLESS STEEL

**PAINT:**

- NONE

PROJECT NAME	
PROPOSAL NUMBER	
SALES ORDER NO.	
CUSTOMER P.O.	

**PROPRIETARY AND CONFIDENTIAL**

THE INFORMATION CONTAINED IN THIS DRAWING IS THE SOLE PROPERTY OF MIRATECH GROUP, LLC. ANY REPRODUCTION IN PART OR AS A WHOLE WITHOUT THE WRITTEN PERMISSION OF MIRATECH GROUP, LLC IS PROHIBITED.

DIMENSIONS ARE IN INCHES UNLESS OTHERWISE SPECIFIED	
DIMENSIONAL TOLERANCES UNLESS OTHERWISE SPECIFIED	
ANGLES:	
MACH: ±1°	INCHES: ±0.125
BEND: ±3°	MILLIMETERS: ±2
DO NOT SCALE DRAWING	
DRAWN	DATE
FES	11/2/2016
REVIEWED BY	DATE
AJM	11/4/2016



**JHEE0-25MN-3-00000000**  
Sales Drawing

DRAWING		JHEE0-25MN-3-00000000 SD		REV
				1
SIZE	SCALE 1:8	WEIGHT: 0 lb	SHEET 1 OF 1	
A				