

| REVISIONS |                                |           |          |          |
|-----------|--------------------------------|-----------|----------|----------|
| REV.      | DESCRIPTION                    | DATE      | SHEET(S) | DRAWN BY |
| 0         | RELEASED FOR CUSTOMER APPROVAL | 11/2/2016 | -        | FES      |
| 1         | UPDATED DRAIN PLUG DESCRIPTION | 11/3/2017 | 1        | SSC      |

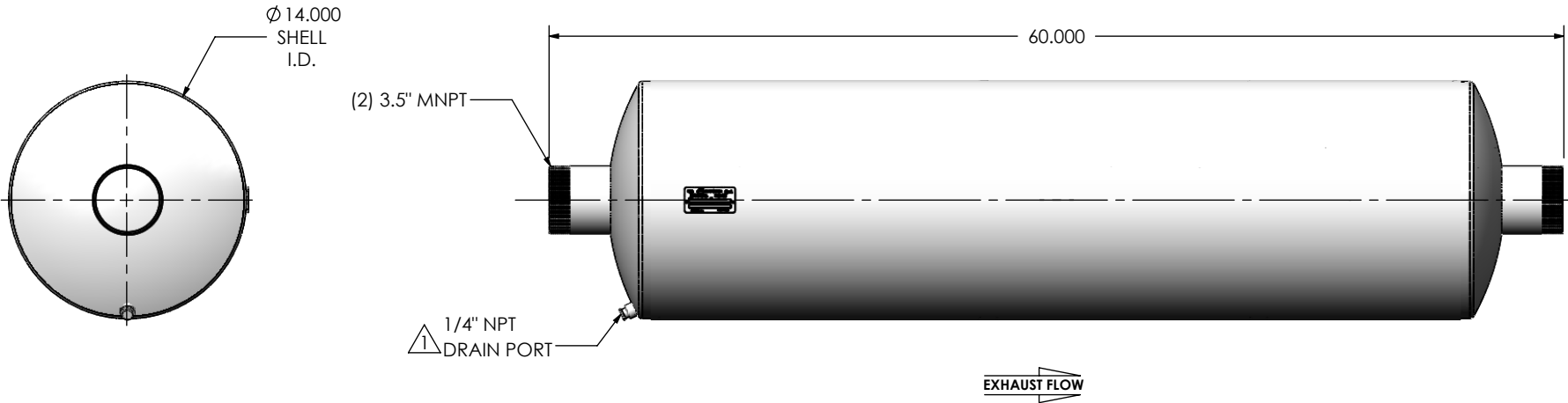

**NOTES:**

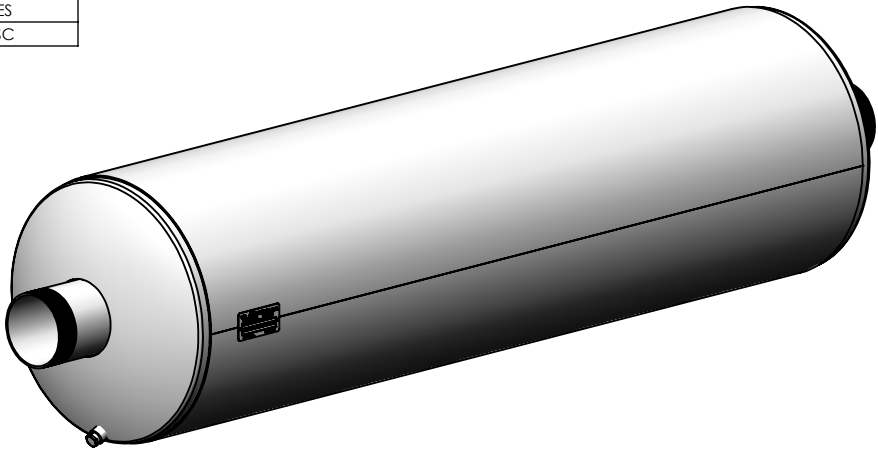

- DO NOT USE EQUIPMENT TO SUPPORT OTHER PARTS OF THE EXHAUST SYSTEM WITHOUT PROPER REINFORCEMENT

**MATERIAL CONSTRUCTION:**

- ALUMINIZED STEEL

**PAINT:**

- HIGH TEMPERATURE BLACK (MIRATECH COATING SYSTEM 5)

|                 |   |   |                                   |   |        |
|-----------------|---|---|-----------------------------------|---|--------|
| PROJECT NAME    | <b>PROPRIETARY AND CONFIDENTIAL</b><br><br>THE INFORMATION CONTAINED IN THIS DRAWING IS THE SOLE PROPERTY OF MIRATECH GROUP, LLC. ANY REPRODUCTION IN PART OR AS A WHOLE WITHOUT THE WRITTEN PERMISSION OF MIRATECH GROUP, LLC IS PROHIBITED. | DIMENSIONS ARE IN INCHES UNLESS OTHERWISE SPECIFIED<br><small>ANGLES:                      DIMENSIONAL TOLERANCES UNLESS OTHERWISE SPECIFIED</small><br>MACH: ±1"                      INCHES:                      ±0.125<br>BEND: ±3"                      MILLIMETERS:                      ±2 |                                   |   |        |
| PROPOSAL NUMBER |   | DO NOT SCALE DRAWING  |                                   | <b>JHEE0-35MN-1-00000000</b><br><b>Sales Drawing</b>  |        |
| SALES ORDER NO. |   | DRAWN: FES                      DATE: 11/2/2016<br>REVIEWED BY: AJM                      DATE: 11/4/2016  | DRAWING: JHEE0-35MN-1-00000000 SD |   | REV: 1 |
| CUSTOMER P.O.   |   | SIZE: A<br>SCALE: 1:10<br>WEIGHT: 94 lb   | SHEET 1 OF 1                      |   |        |