

REVISIONS				
REV.	DESCRIPTION	DATE	SHEET(S)	DRAWN BY
0	ORIGINAL RELEASE	11/02/2016	-	FES
1	UPDATE DRAIN PLUG DESCRIPTION	11/6/2017	-	CSF

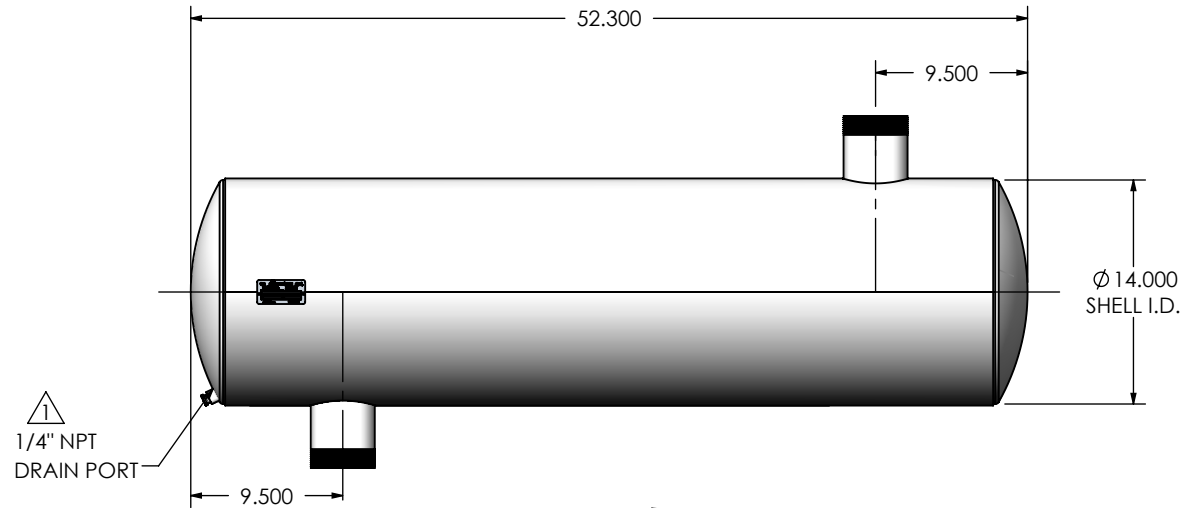
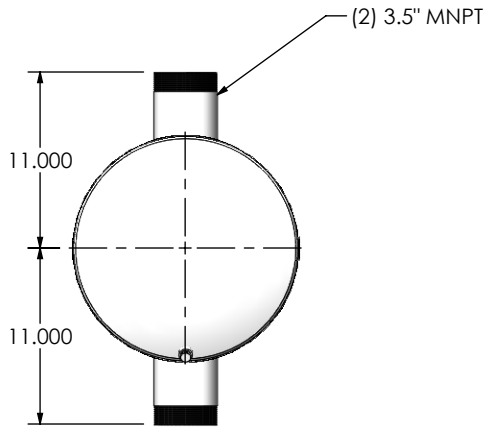
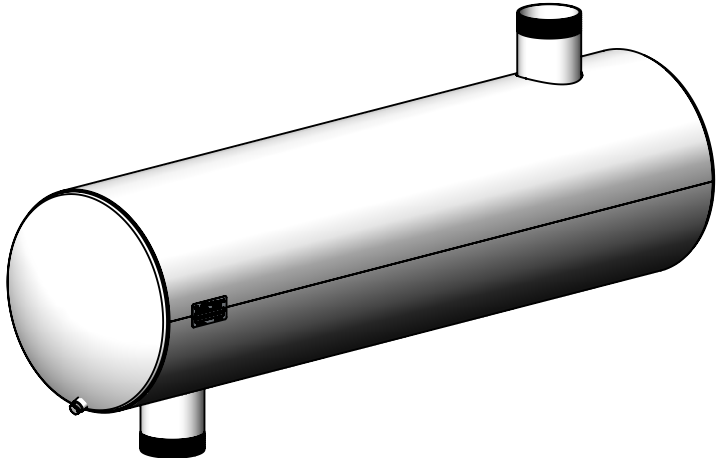

EXHAUST FLOW

**NOTES:**

- DO NOT USE EQUIPMENT TO SUPPORT OTHER PARTS OF THE EXHAUST SYSTEM WITHOUT PROPER REINFORCEMENT

**MATERIAL CONSTRUCTION:**

- ALUMINIZED STEEL

**PAINT:**

- HIGH TEMPERATURE BLACK (MIRATECH COATING SYSTEM 5)

PROJECT NAME	<b>PROPRIETARY AND CONFIDENTIAL</b>  THE INFORMATION CONTAINED IN THIS DRAWING IS THE SOLE PROPERTY OF MIRATECH GROUP, LLC. ANY REPRODUCTION IN PART OR AS A WHOLE WITHOUT THE WRITTEN PERMISSION OF MIRATECH GROUP, LLC IS PROHIBITED.	DIMENSIONS ARE IN INCHES UNLESS OTHERWISE SPECIFIED			<b>JHGA0-35MN-1-000029H5</b> <b>Sales Drawing</b>	
PROPOSAL NUMBER		<small>DIMENSIONAL TOLERANCES UNLESS OTHERWISE SPECIFIED</small> ANGLES: MACH: ±1° INCHES: ±0.125 BEND: ±3° MILLIMETERS: ±2				
SALES ORDER NO.		DO NOT SCALE DRAWING		DRAWING		
CUSTOMER P.O.		DRAWN: FES REVIEWED BY: AJM	DATE: 11/2/2016 DATE: 11/4/2016	JHGA0-35MN-1-000029H5 SD SCALE 1:12 WEIGHT: 96 lb	REV 1 SHEET 1 OF 1	