

REVISIONS				
REV.	DESCRIPTION	DATE	SHEET(S)	DRAWN BY
0	ORIGINAL RELEASE	11/2/2016	-	FES
1	UPDATE DRAIN PORT DESCRIPTION	11/6/2017	-	CSF

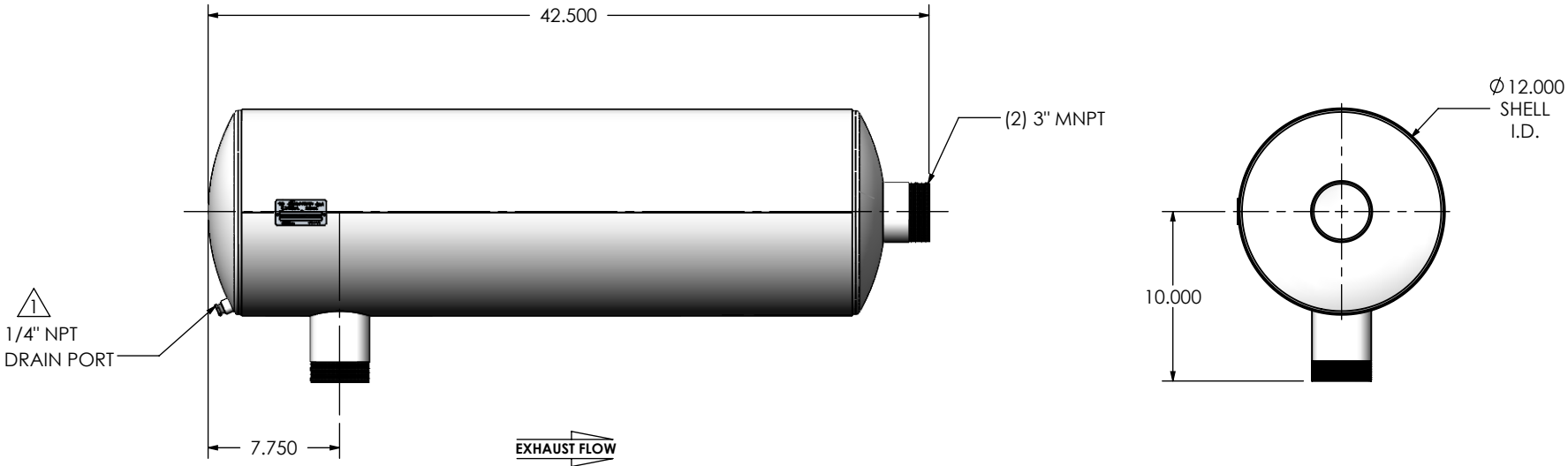

NOTES:

- DO NOT USE EQUIPMENT TO SUPPORT OTHER PARTS OF THE EXHAUST SYSTEM WITHOUT PROPER REINFORCEMENT

MATERIAL CONSTRUCTION:

- 304 STAINLESS STEEL

PAINT:

- NONE

PROJECT NAME	PROPRIETARY AND CONFIDENTIAL THE INFORMATION CONTAINED IN THIS DRAWING IS THE SOLE PROPERTY OF MIRATECH GROUP, LLC. ANY REPRODUCTION IN PART OR AS A WHOLE WITHOUT THE WRITTEN PERMISSION OF MIRATECH GROUP, LLC IS PROHIBITED.
PROPOSAL NUMBER	
SALES ORDER NO.	
CUSTOMER P.O.	

DIMENSIONS ARE IN INCHES UNLESS OTHERWISE SPECIFIED <small>DIMENSIONAL TOLERANCES UNLESS OTHERWISE SPECIFIED</small> ANGLES: MACH: ±1° INCHES: ±0.125 BEND: ±3° MILLIMETERS: ±2	
DO NOT SCALE DRAWING	
DRAWN	DATE
FES	11/2/2016
REVIEWED BY	DATE
AJM	11/4/2016



JHGE0-03MN-3-00000028
Sales Drawing

DRAWING		JHGE0-03MN-3-00000028 SD		REV	1
SIZE	A	SCALE	1:10	WEIGHT:	0 lb
					SHEET 1 OF 1