

REVISIONS				
REV.	DESCRIPTION	DATE	SHEET(S)	DRAWN BY
0	RELEASED FOR CUSTOMER APPROVAL	8/8/2016	-	JFS
1	UPDATED DRAIN PLUG DESCRIPTION	10/31/2017	1	SSC

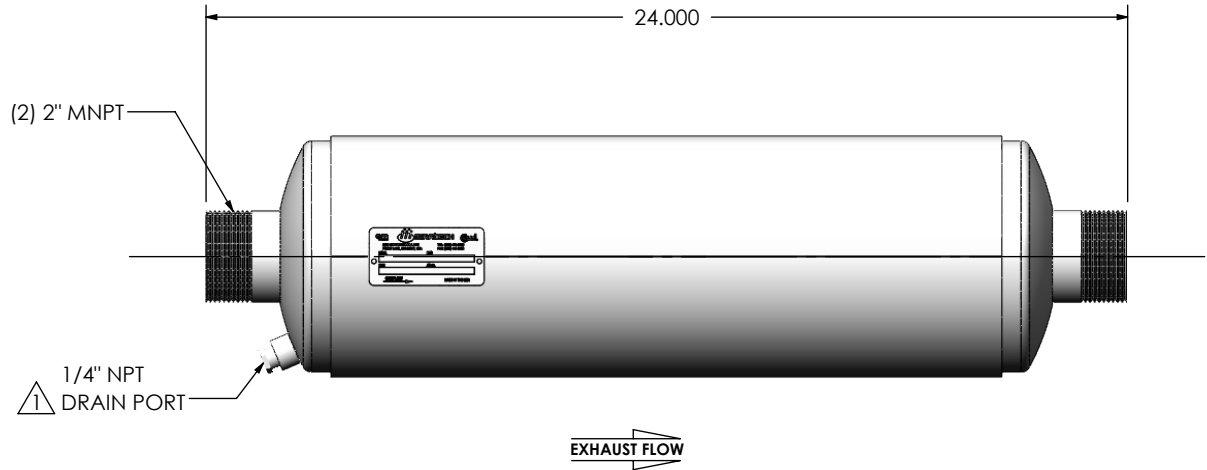
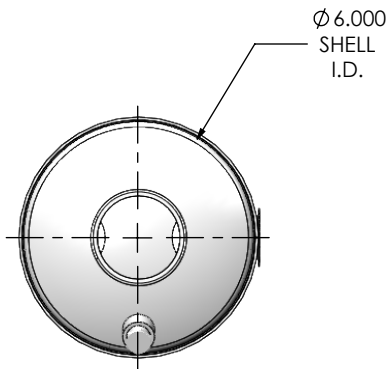
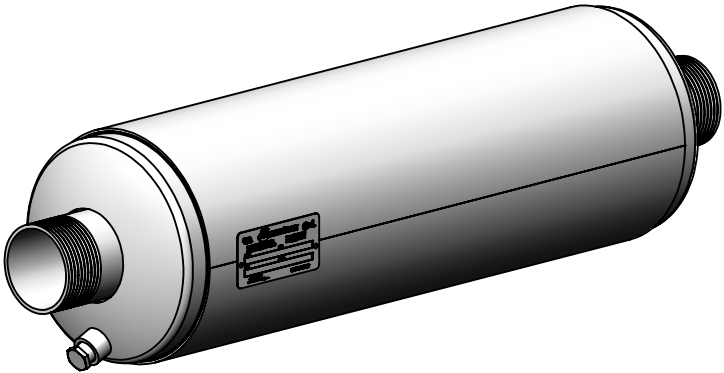

**NOTES:**

- DO NOT USE EQUIPMENT TO SUPPORT OTHER PARTS OF THE EXHAUST SYSTEM WITHOUT PROPER REINFORCEMENT

**MATERIAL CONSTRUCTION:**

- ALUMINIZED STEEL

**PAINT:**



- HIGH TEMPERATURE BLACK (MIRATECH COATING SYSTEM 5)

PROJECT NAME	
PROPOSAL NUMBER	
SALES ORDER NO.	
CUSTOMER P.O.	

**PROPRIETARY AND CONFIDENTIAL**

THE INFORMATION CONTAINED IN THIS DRAWING IS THE SOLE PROPERTY OF MIRATECH GROUP, LLC. ANY REPRODUCTION IN PART OR AS A WHOLE WITHOUT THE WRITTEN PERMISSION OF MIRATECH GROUP, LLC IS PROHIBITED.

DIMENSIONS ARE IN INCHES UNLESS OTHERWISE SPECIFIED	
DIMENSIONAL TOLERANCES UNLESS OTHERWISE SPECIFIED	
ANGLES	
MACH: ±1°	INCHES: ±0.125
BEND: ±3°	MILLIMETERS: ±2
DO NOT SCALE DRAWING	
DRAWN	DATE
JFS	08/08/2016
REVIEWED BY	DATE
EQJ	08/19/2016

		
<b>JIEE0-02MN-1-00000000</b> <b>Sales Drawing</b>		
DRAWING		REV
JIEE0-02MN-1-00000000 SD		1
SIZE	SCALE 1:5	WEIGHT: 16 lb
A		SHEET 1 OF 1