

REVISIONS				
REV.	DESCRIPTION	DATE	SHEET(S)	DRAWN BY
0	RELEASED FOR CUSTOMER APPROVAL	8/8/2016	-	JFS
1	UPDATED DRAIN PLUG DESCRIPTION	11/1/2017	1	SSC

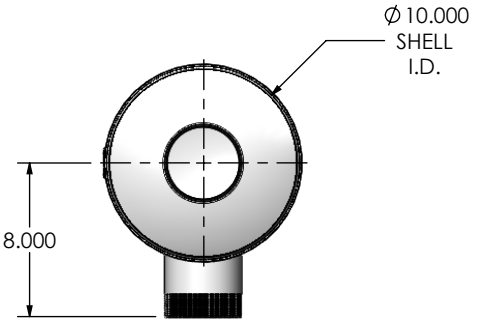
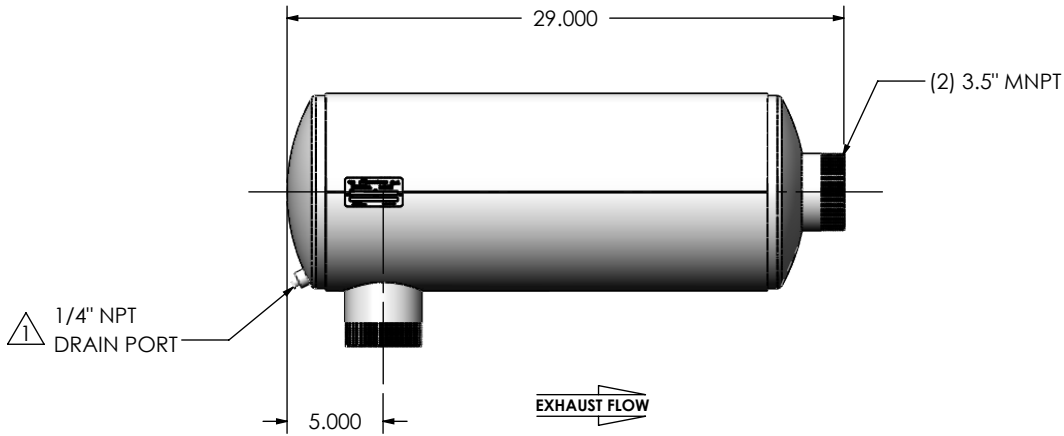
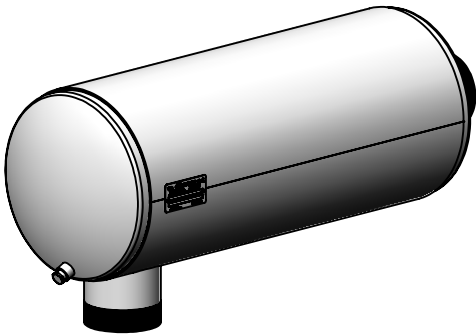

NOTES:

- DO NOT USE EQUIPMENT TO SUPPORT OTHER PARTS OF THE EXHAUST SYSTEM WITHOUT PROPER REINFORCEMENT

MATERIAL CONSTRUCTION:

- ALUMINIZED STEEL

PAINT:

- HIGH TEMPERATURE BLACK (MIRATECH COATING SYSTEM 5)

PROJECT NAME	PROPRIETARY AND CONFIDENTIAL THE INFORMATION CONTAINED IN THIS DRAWING IS THE SOLE PROPERTY OF MIRATECH GROUP, LLC. ANY REPRODUCTION IN PART OR AS A WHOLE WITHOUT THE WRITTEN PERMISSION OF MIRATECH GROUP, LLC IS PROHIBITED.
PROPOSAL NUMBER	
SALES ORDER NO.	
CUSTOMER P.O.	

DIMENSIONS ARE IN INCHES UNLESS OTHERWISE SPECIFIED	
DIMENSIONAL TOLERANCES UNLESS OTHERWISE SPECIFIED	
ANGLES:	
MACH: $\pm 1^{\circ}$	INCHES: ± 0.125
BEND: $\pm 3^{\circ}$	MILLIMETERS: ± 2
DO NOT SCALE DRAWING	
DRAWN	DATE
JFS	08/08/2016
REVIEWED BY	DATE
EQJ	08/19/2016

JIGE0-35MN-1-000001F Sales Drawing			
DRAWING		JIGE0-35MN-1-000001F SD	
REV	1	SCALE	1:10
SIZE	A	WEIGHT	35 lb
		SHEET 1 OF 1	