

REVISIONS				
REV.	DESCRIPTION	DATE	SHEET(S)	DRAWN BY
0	ORIGINAL RELEASE	08/08/2016	1	JFS
1	UPDATED DRAIN PLUG DESCRIPTION	10/31/2017	1	FES

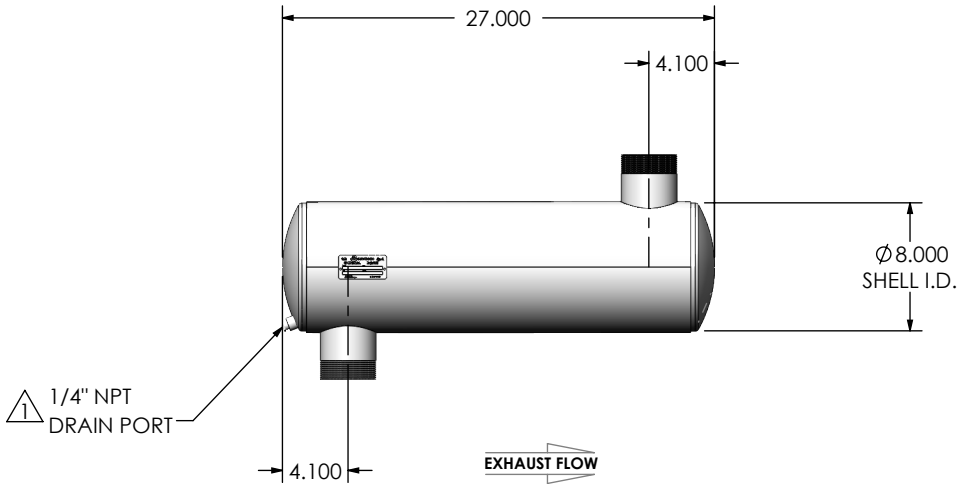
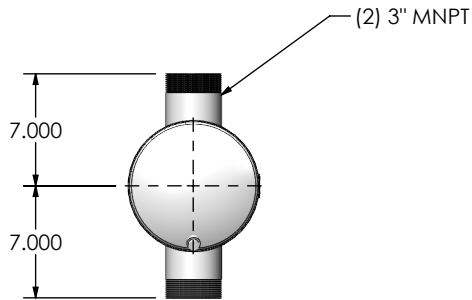
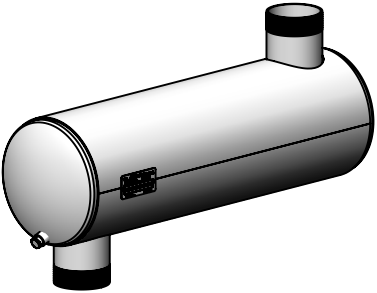

**NOTES:**

- DO NOT USE EQUIPMENT TO SUPPORT OTHER PARTS OF THE EXHAUST SYSTEM WITHOUT PROPER REINFORCEMENT

**MATERIAL CONSTRUCTION:**

- CARBON STEEL

**PAINT:**

- HIGH TEMPERATURE BLACK (MIRATECH COATING SYSTEM 5)

PROJECT NAME	<b>PROPRIETARY AND CONFIDENTIAL</b>  THE INFORMATION CONTAINED IN THIS DRAWING IS THE SOLE PROPERTY OF MIRATECH GROUP, LLC. ANY REPRODUCTION IN PART OR AS A WHOLE WITHOUT THE WRITTEN PERMISSION OF MIRATECH GROUP, LLC IS PROHIBITED.
PROPOSAL NUMBER	
SALES ORDER NO.	
CUSTOMER P.O.	

DIMENSIONS ARE IN INCHES UNLESS OTHERWISE SPECIFIED	
<small>DIMENSIONAL TOLERANCES UNLESS OTHERWISE SPECIFIED</small> <small>ANGLES:</small> MACH: ±1° BEND: ±3°	<small>INCHES: ±0.125</small> <small>MILLIMETERS: ±2</small>
DO NOT SCALE DRAWING	
<small>DRAWN</small> JFS	<small>DATE</small> 08/08/2016
<small>REVIEWED BY</small> EQJ	<small>DATE</small> 08/19/2016



**JRGA0-03MN-2-00000ZAQ**  
Sales Drawing

DRAWING		JRGA0-03MN-2-00000ZAQ SD		REV <b>1</b>
SIZE <b>A</b>	SCALE 1:12	WEIGHT: 25 lb	SHEET 1 OF 1	