

REVISIONS				
REV.	DESCRIPTION	DATE	SHEET(S)	DRAWN BY
1	UPDATED DRAIN PLUG DESCRIPTION	10/31/2017	1	FES

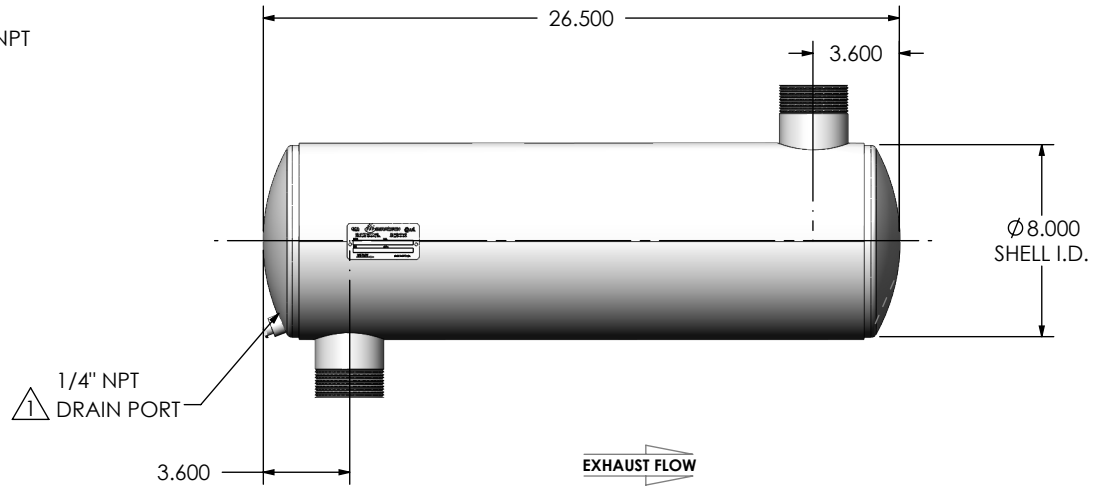
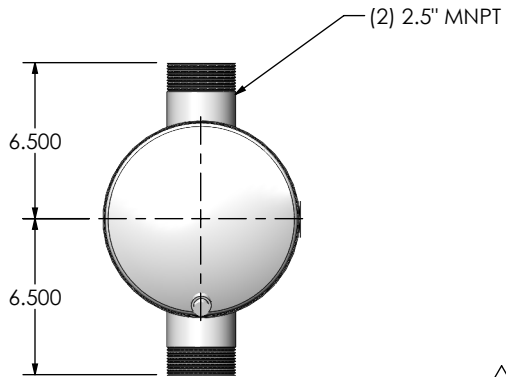
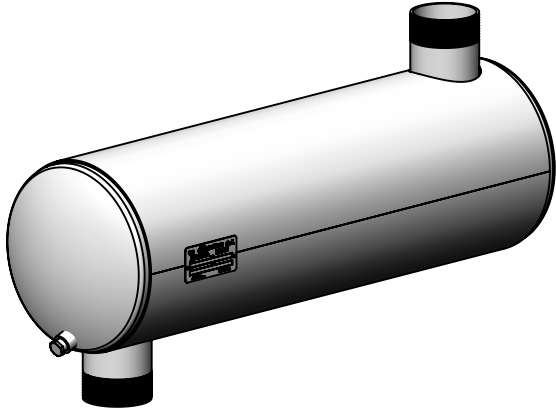

**NOTES:**

- DO NOT USE EQUIPMENT TO SUPPORT OTHER PARTS OF THE EXHAUST SYSTEM WITHOUT PROPER REINFORCEMENT

**MATERIAL CONSTRUCTION:**

- CARBON STEEL

**PAINT:**

- HIGH TEMPERATURE BLACK (MIRATECH COATING SYSTEM 5)

PROJECT NAME	<b>PROPRIETARY AND CONFIDENTIAL</b>  THE INFORMATION CONTAINED IN THIS DRAWING IS THE SOLE PROPERTY OF MIRATECH GROUP, LLC. ANY REPRODUCTION IN PART OR AS A WHOLE WITHOUT THE WRITTEN PERMISSION OF MIRATECH GROUP, LLC IS PROHIBITED.
PROPOSAL NUMBER	
SALES ORDER NO.	
CUSTOMER P.O.	

DIMENSIONS ARE IN INCHES UNLESS OTHERWISE SPECIFIED	
<small>DIMENSIONAL TOLERANCES UNLESS OTHERWISE SPECIFIED</small> ANGLES: ±1° MACH: ±.015" BEND: ±3°	<small>DIMENSIONAL TOLERANCES UNLESS OTHERWISE SPECIFIED</small> INCHES: ±0.125" MILLIMETERS: ±2
DO NOT SCALE DRAWING	
DRAWN: JFS	DATE: 08/08/2016
REVIEWED BY: EQJ	DATE: 08/19/2016



**JRGA0-25MN-2-00000V4A**  
Sales Drawing

DRAWING: JRGA0-25MN-2-00000V4A SD		REV: 1
SIZE: A	SCALE: 1:8	WEIGHT: 23 lb
		SHEET 1 OF 1