

REVISIONS				
REV.	DESCRIPTION	DATE	SHEET(S)	DRAWN BY
0	ORIGINAL RELEASE	08/08/2016	1	JFS
1	UPDATED DRAIN PLUG DESCRIPTION	11/1/2017	1	FES

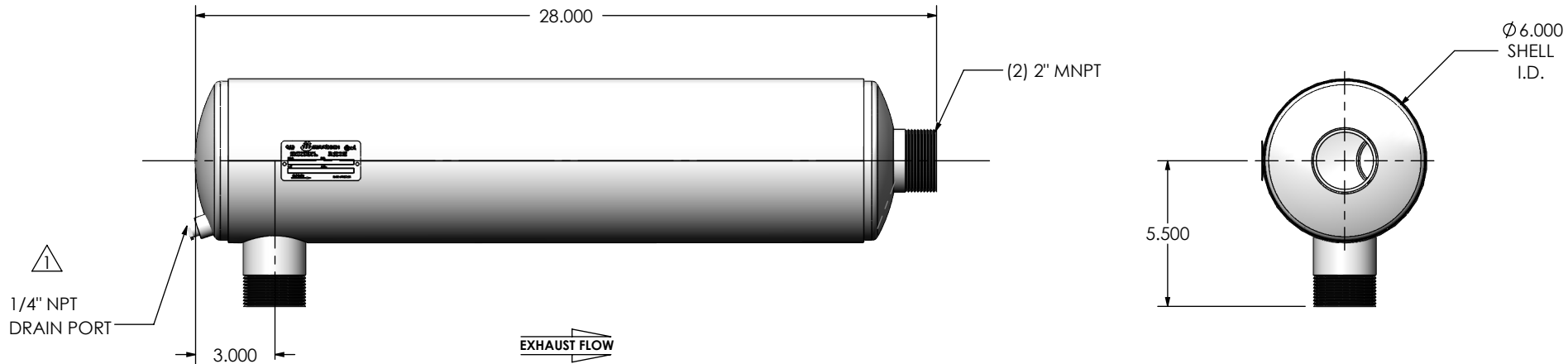
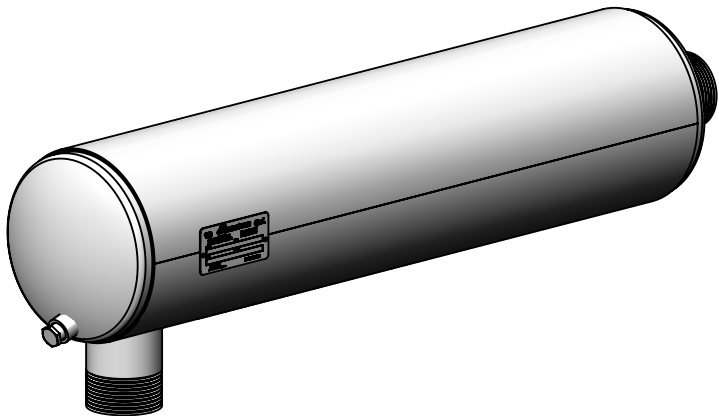

NOTES:

- DO NOT USE EQUIPMENT TO SUPPORT OTHER PARTS OF THE EXHAUST SYSTEM WITHOUT PROPER REINFORCEMENT

MATERIAL CONSTRUCTION:

- CARBON STEEL

PAINT:

- HIGH TEMPERATURE BLACK (MIRATECH COATING SYSTEM 5)

PROJECT NAME	PROPRIETARY AND CONFIDENTIAL THE INFORMATION CONTAINED IN THIS DRAWING IS THE SOLE PROPERTY OF MIRATECH GROUP, LLC. ANY REPRODUCTION IN PART OR AS A WHOLE WITHOUT THE WRITTEN PERMISSION OF MIRATECH GROUP, LLC IS PROHIBITED.
PROPOSAL NUMBER	
SALES ORDER NO.	
CUSTOMER P.O.	

PROPRIETARY AND CONFIDENTIAL
 THE INFORMATION CONTAINED IN THIS DRAWING IS THE SOLE PROPERTY OF MIRATECH GROUP, LLC. ANY REPRODUCTION IN PART OR AS A WHOLE WITHOUT THE WRITTEN PERMISSION OF MIRATECH GROUP, LLC IS PROHIBITED.

DIMENSIONS ARE IN INCHES UNLESS OTHERWISE SPECIFIED	
DIMENSIONAL TOLERANCES UNLESS OTHERWISE SPECIFIED	
ANGLES	
MACH: ±1"	INCHES: ±0.125
BEND: ±3"	MILLIMETERS: ±2
DO NOT SCALE DRAWING	
DRAWN	DATE
JFS	08/08/2016
REVIEWED BY	DATE
EQJ	08/19/2016

JRGE0-02MN-2-000000V Sales Drawing			
DRAWING		REV	
JRGE0-02MN-2-000000V SD		1	
SIZE	SCALE 1:6	WEIGHT: 18 lb	SHEET 1 OF 1