

REVISIONS				
REV.	DESCRIPTION	DATE	SHEET(S)	DRAWN BY
0	ORIGINAL RELEASE	08/08/2016	1	JFS
1	UPDATED DRAIN PLUG DESCRIPTION	11/1/2017	1	FES

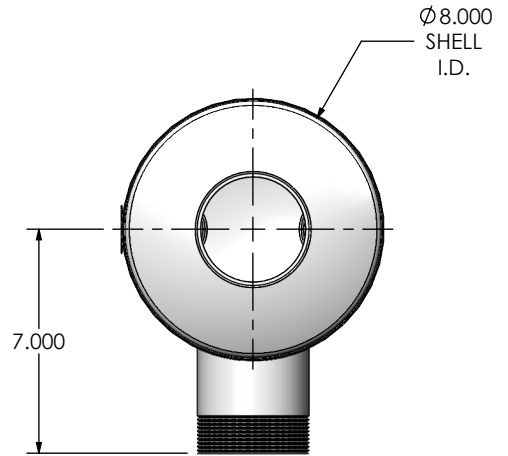
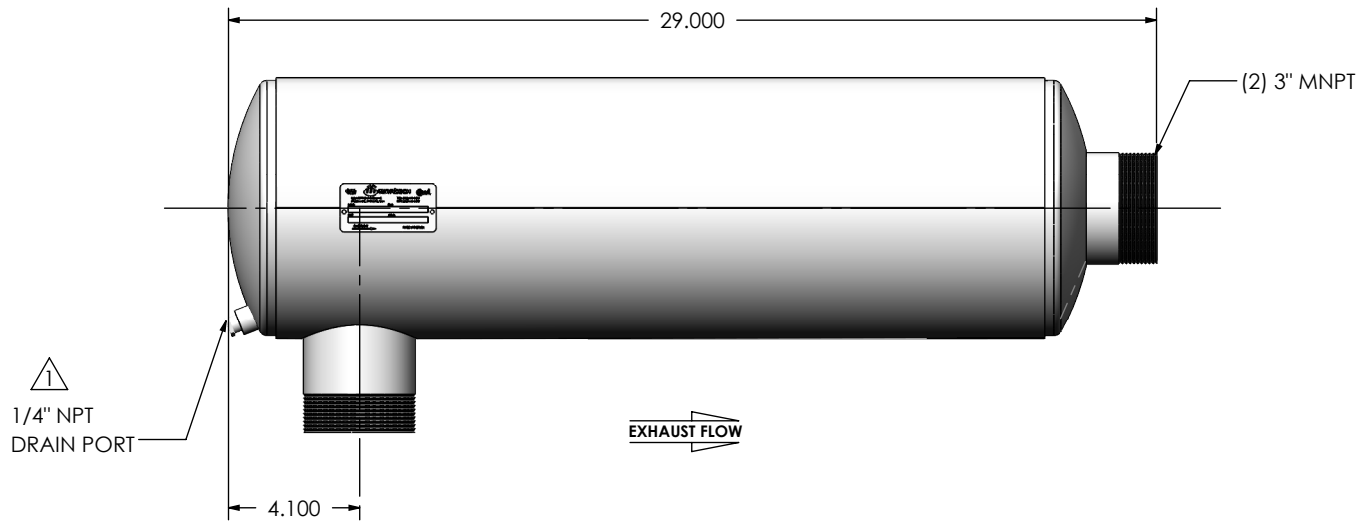
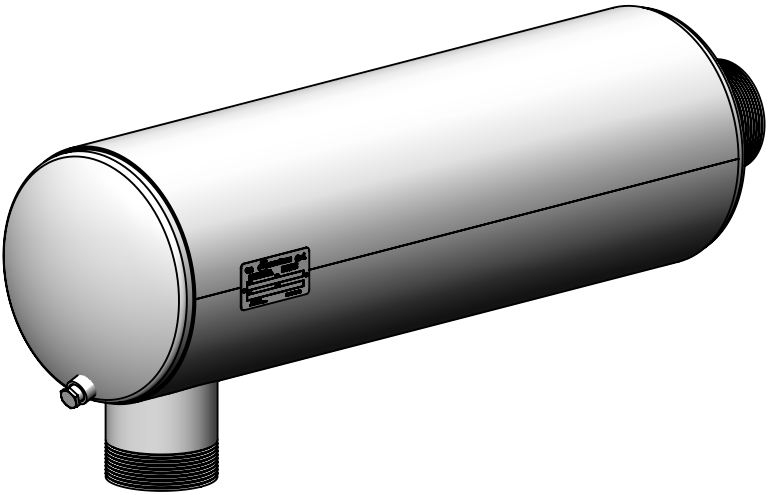

**NOTES:**

- DO NOT USE EQUIPMENT TO SUPPORT OTHER PARTS OF THE EXHAUST SYSTEM WITHOUT PROPER REINFORCEMENT

**MATERIAL CONSTRUCTION:**

- CARBON STEEL

**PAINT:**

- HIGH TEMPERATURE BLACK (MIRATECH COATING SYSTEM 5)

PROJECT NAME	<b>PROPRIETARY AND CONFIDENTIAL</b> THE INFORMATION CONTAINED IN THIS DRAWING IS THE SOLE PROPERTY OF MIRATECH GROUP, LLC. ANY REPRODUCTION IN PART OR AS A WHOLE WITHOUT THE WRITTEN PERMISSION OF MIRATECH GROUP, LLC IS PROHIBITED.
PROPOSAL NUMBER	
SALES ORDER NO.	
CUSTOMER P.O.	

**PROPRIETARY AND CONFIDENTIAL**

THE INFORMATION CONTAINED IN THIS DRAWING IS THE SOLE PROPERTY OF MIRATECH GROUP, LLC. ANY REPRODUCTION IN PART OR AS A WHOLE WITHOUT THE WRITTEN PERMISSION OF MIRATECH GROUP, LLC IS PROHIBITED.

DIMENSIONS ARE IN INCHES UNLESS OTHERWISE SPECIFIED	
DIMENSIONAL TOLERANCES UNLESS OTHERWISE SPECIFIED ANGLES: MACH: ±1° BEND: ±3°	INCHES: ±0.125 MILLIMETERS: ±2
DO NOT SCALE DRAWING	
DRAWN	DATE
JFS	08/08/2016
REVIEWED BY	DATE
EQJ	08/19/2016

<b>JRGE0-03MN-2-00000016</b> <b>Sales Drawing</b>			
DRAWING		REV	
JRGE0-03MN-2-00000016 SD		1	
SIZE	SCALE 1:6	WEIGHT: 25 lb	SHEET 1 OF 1
A			