

(2) 18" FF FLANGE
150 lb ANSI
STANDARD
BOLT PATTERN

EXHAUST FLOW

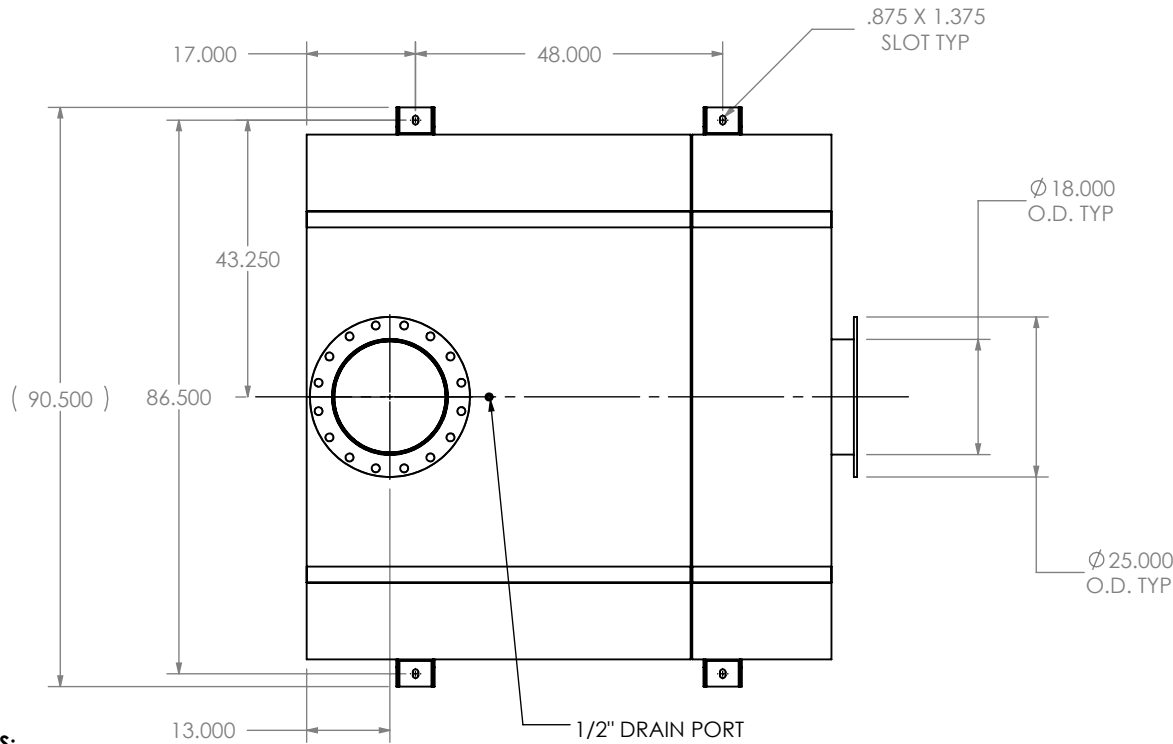

NOTES:

- DO NOT USE EQUIPMENT TO SUPPORT OTHER PARTS OF THE EXHAUST SYSTEM WITHOUT PROPER REINFORCEMENT

MATERIAL CONSTRUCTION:



- CARBON STEEL

PAINT:

- HIGH TEMPERATURE BLACK (MIRATECH COATING SYSTEM 5)

PROJECT NAME	PROPRIETARY AND CONFIDENTIAL THE INFORMATION CONTAINED IN THIS DRAWING IS THE SOLE PROPERTY OF MIRATECH GROUP, LLC. ANY REPRODUCTION IN PART OR AS A WHOLE WITHOUT THE WRITTEN PERMISSION OF MIRATECH GROUP, LLC IS PROHIBITED.
PROPOSAL NUMBER	
SALES ORDER NO.	
CUSTOMER P.O.	

DIMENSIONS ARE IN INCHES UNLESS OTHERWISE SPECIFIED	
DIMENSIONAL TOLERANCES UNLESS OTHERWISE SPECIFIED	
ANGLES	
MACH: ±1"	INCHES: ±0.125
BEND: ±3"	MILLIMETERS: ±2
DO NOT SCALE DRAWING	
DRAWN	DATE
FES	9/16/2016
REVIEWED BY	DATE
AJM	09/31/2016

 MIRATECH		
OCBE0T-18PF-2-0000003Q Sales Drawing		
DRAWING		REV
OCBE0T-18PF-2-0000003Q SD		0
SIZE	SCALE 1:30	WEIGHT: 1224 lb
A		SHEET 1 OF 1