

(2) 24" FF FLANGE
150 lb ANSI
STANDARD
BOLT PATTERN

EXHAUST FLOW

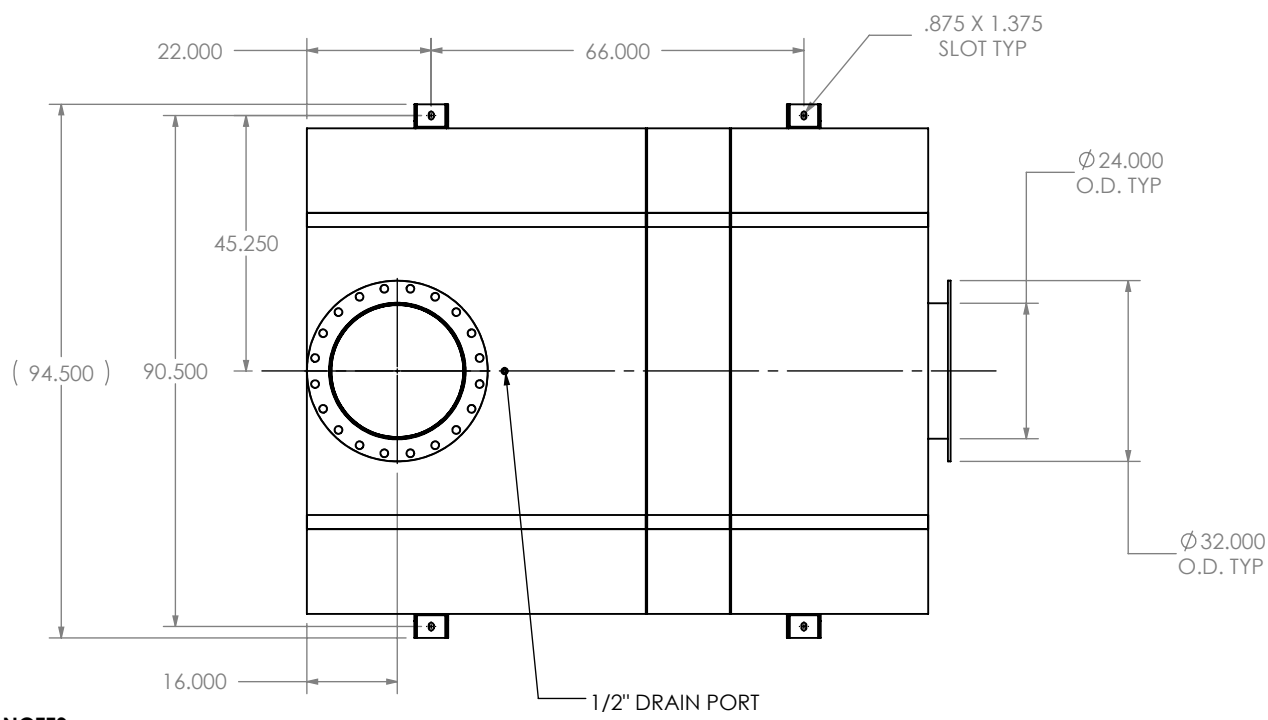

NOTES:

- DO NOT USE EQUIPMENT TO SUPPORT OTHER PARTS OF THE EXHAUST SYSTEM WITHOUT PROPER REINFORCEMENT

MATERIAL CONSTRUCTION:

- CARBON STEEL

PAINT:

- HIGH TEMPERATURE BLACK (MIRATECH COATING SYSTEM 5)

PROJECT NAME	PROPRIETARY AND CONFIDENTIAL THE INFORMATION CONTAINED IN THIS DRAWING IS THE SOLE PROPERTY OF MIRATECH GROUP, LLC. ANY REPRODUCTION IN PART OR AS A WHOLE WITHOUT THE WRITTEN PERMISSION OF MIRATECH GROUP, LLC IS PROHIBITED.
PROPOSAL NUMBER	
SALES ORDER NO.	
CUSTOMER P.O.	

DIMENSIONS ARE IN INCHES UNLESS OTHERWISE SPECIFIED

ANGLES	DIMENSIONAL TOLERANCES UNLESS OTHERWISE SPECIFIED	
MACH: ±1"	INCHES: ±0.125	
BEND: ±3°	MILLIMETERS: ±2	

DO NOT SCALE DRAWING

DRAWN	DATE
FES	9/16/2016
REVIEWED BY	DATE
AJM	09/31/2016

OCBE0T-24PF-2-0000004K Sales Drawing			
DRAWING		REV	
OCBE0T-24PF-2-0000004K SD		0	
SIZE	SCALE	WEIGHT	SHEET
A	1:34	1832 lb	1 OF 1