

FRONT VIEW

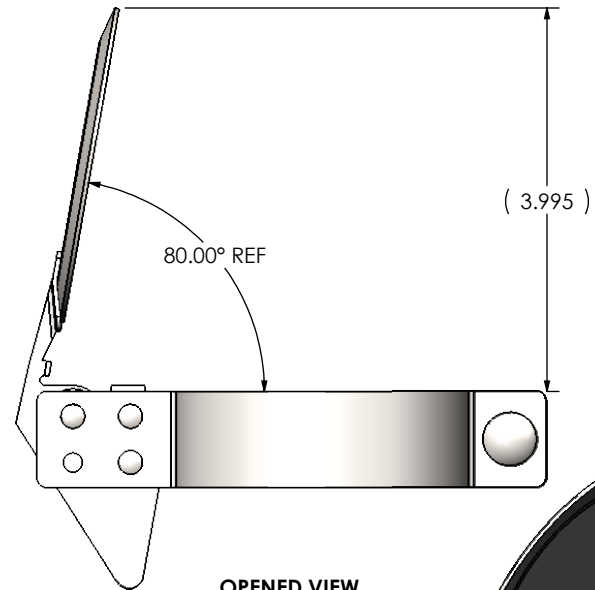

OPENED VIEW

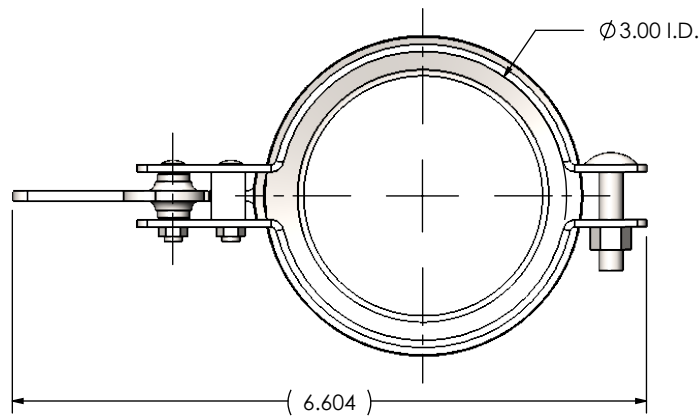

BOTTOM VIEW

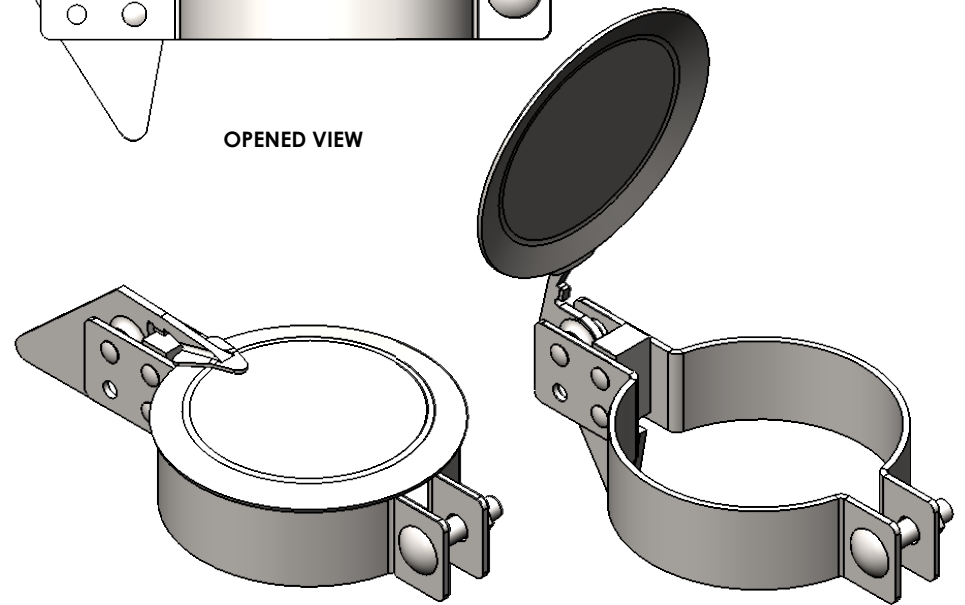

**NOTES:**

- STACK SHOULD EXTEND ABOVE CLAMP APPROXIMATELY 0.25" WHEN PROPERLY INSTALLED

**MATERIAL CONSTRUCTION:**

- CARBON STEEL

**PAINT:**

- HIGH TEMPERATURE BLACK

PROJECT NAME
PROPOSAL NUMBER
SALES ORDER NO.
CUSTOMER P.O.

**PROPRIETARY AND CONFIDENTIAL**



THE INFORMATION CONTAINED IN THIS DRAWING IS THE SOLE PROPERTY OF MIRATECH GROUP, LLC. ANY REPRODUCTION IN PART OR AS A WHOLE WITHOUT THE WRITTEN PERMISSION OF MIRATECH GROUP, LLC IS PROHIBITED.

DIMENSIONS ARE IN INCHES UNLESS OTHERWISE SPECIFIED

DIMENSIONAL TOLERANCES UNLESS OTHERWISE SPECIFIED	
ANGLES	
MACH: ±1°	INCHES: ±0.125
BEND: ±3°	MILLIMETERS: ±2

DO NOT SCALE DRAWING

DRAWN	DATE
SSC	4/13/2017
REVIEWED BY	DATE
AJM	4/13/2017

			
<b>RC-0300</b> <b>Sales Drawing</b>			
DRAWING		RC-0300 SD	
REV	SCALE 1:2		WEIGHT: 1 lb
0	SIZE A		SHEET 1 OF 1