

FRONT VIEW

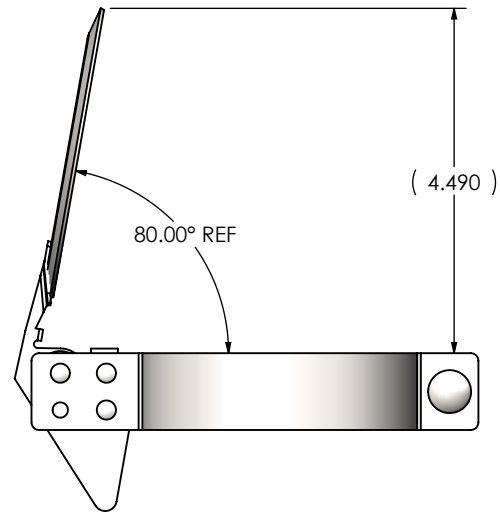

OPENED VIEW

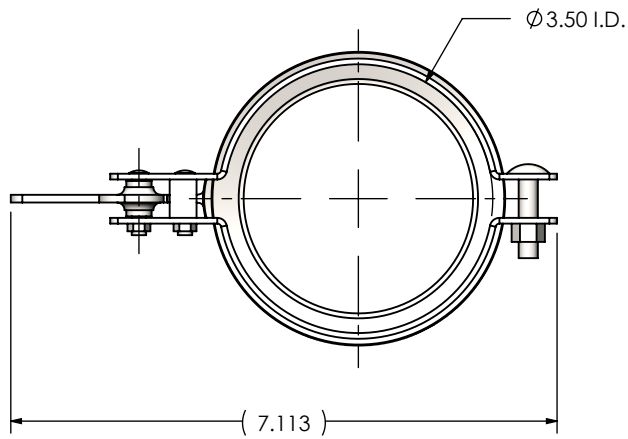

BOTTOM VIEW

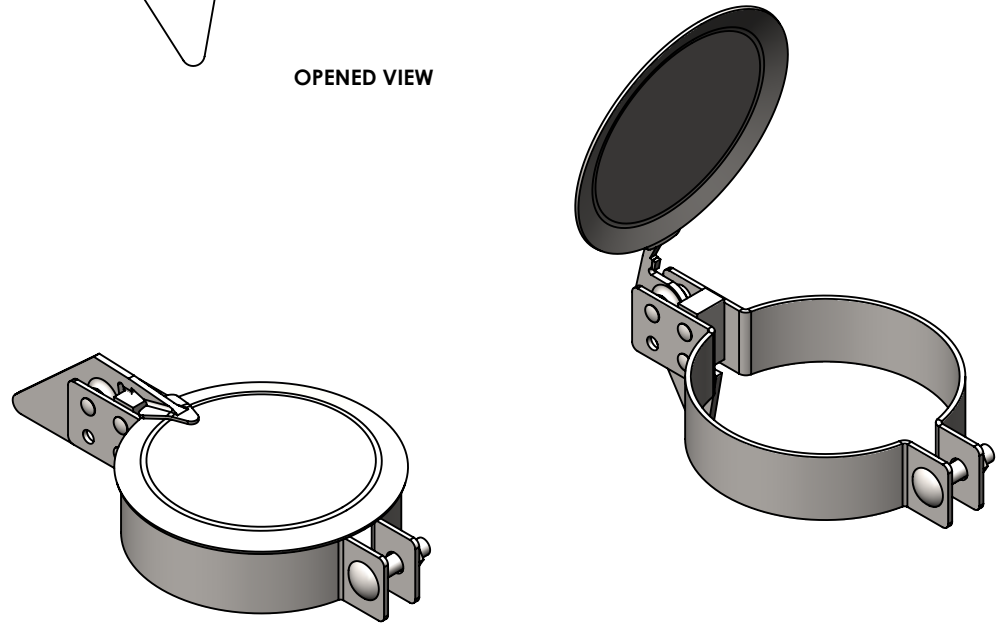

**NOTES:**

- STACK SHOULD EXTEND ABOVE CLAMP APPROXIMATELY 0.25" WHEN PROPERLY INSTALLED

**MATERIAL CONSTRUCTION:**

- CARBON STEEL

**PAINT:**

- HIGH TEMPERATURE BLACK

|                 |
|-----------------|
| PROJECT NAME    |
| PROPOSAL NUMBER |
| SALES ORDER NO. |
| CUSTOMER P.O.   |

**PROPRIETARY AND CONFIDENTIAL**

THE INFORMATION CONTAINED IN THIS DRAWING IS THE SOLE PROPERTY OF MIRATECH GROUP, LLC. ANY REPRODUCTION IN PART OR AS A WHOLE WITHOUT THE WRITTEN PERMISSION OF MIRATECH GROUP, LLC IS PROHIBITED.

DIMENSIONS ARE IN INCHES UNLESS OTHERWISE SPECIFIED

|   |                 |
|---|-----------------|
| DIMENSIONAL TOLERANCES UNLESS OTHERWISE SPECIFIED |                 |
| ANGLES  |                 |
| MACH: ±1°   | INCHES: ±0.125  |
| BEND: ±3°   | MILLIMETERS: ±2 |

DO NOT SCALE DRAWING

|             |            |
|-------------|------------|
| DRAWN       | DATE       |
| MAM         | 12/04/2017 |
| REVIEWED BY | DATE       |
| CAC         | 12/04/2017 |

|  |   |              |              |
|--|---|--------------|--------------|
|  |   |              |              |
| <b>RC-0350</b><br><b>Sales Drawing</b> |   |              |              |
| DRAWING                                |   | RC-0350 SD   |              |
| REV                                    | 0 | SCALE 1:2    | WEIGHT: 1 lb |
|  |   | SHEET 1 OF 1 |              |