

FRONT VIEW

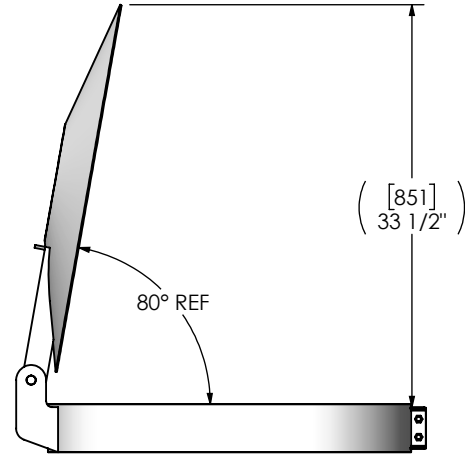

OPENED VIEW

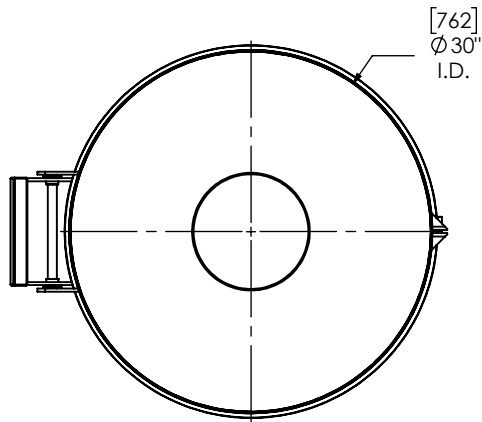

BOTTOM VIEW

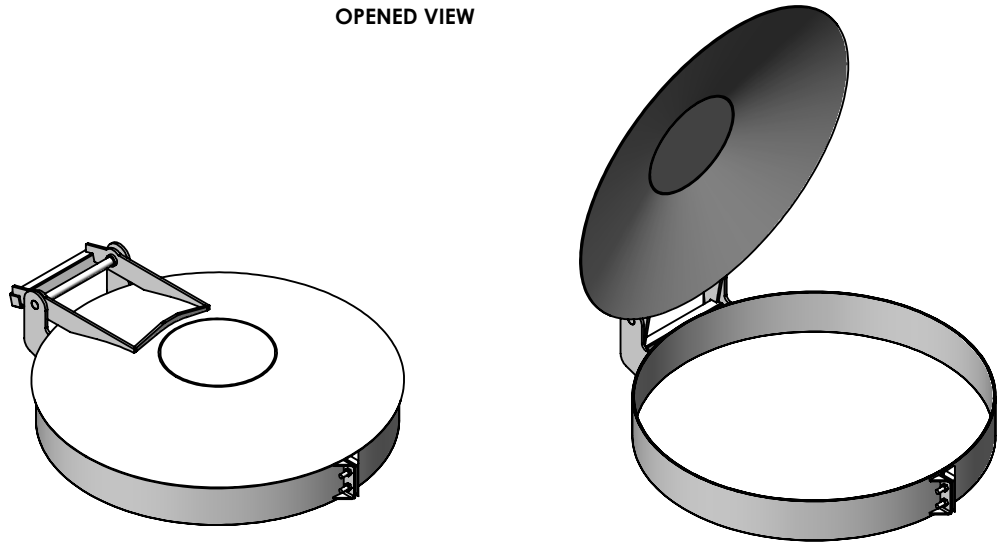

**NOTES:**



- DO NOT USE EQUIPMENT TO SUPPORT OTHER PARTS OF THE EXHAUST SYSTEM WITHOUT PROPER REINFORCEMENT

**MATERIAL CONSTRUCTION:**

- 304 STAINLESS STEEL

**PAINT:**

- NO PAINT  
(MIRATECH COATING SYSTEM 4)

PROJECT NAME	<b>PROPRIETARY AND CONFIDENTIAL</b>  THE INFORMATION CONTAINED IN THIS DRAWING IS THE SOLE PROPERTY OF MIRATECH GROUP, LLC. ANY REPRODUCTION IN PART OR AS A WHOLE WITHOUT THE WRITTEN PERMISSION OF MIRATECH GROUP, LLC IS PROHIBITED.	DIMENSIONS ARE APPROXIMATE IN INCHES UNLESS OTHERWISE SPECIFIED <small>DIMENSIONAL TOLERANCES UNLESS OTHERWISE SPECIFIED</small> ANGLES MACH: ±2" INCHES: ±0.125 BEND: ±3" MILLIMETERS: ±5		 		
PROPOSAL NUMBER		<b>DO NOT SCALE DRAWING</b>		<b>RCHD-3000-3</b> <b>Sales Drawing</b>		
SALES ORDER NO.		DRAWN SSC	DATE 9/18/2018	DRAWING RCHD-3000-3 SD		REV 0
CUSTOMER P.O.		REVIEWED BY CAC	DATE 9/18/2018	SIZE A	SCALE 1:16	WEIGHT: 67 lb