

ITEM NO.	QTY.	PART NAME	MATERIAL	DESCRIPTION	SHEET DETAIL
1	2	BAND	CS	SHEET: 10 GA	2
2	2	FOOT	CS	SHEET: 10 GA	3
3	2	BOLT	CS	BOLT: HEX CS 0.50-13UNC X 2.50	-
4	2	NUT	CS	NUT: HEX CS 0.50-13UNC	-
5	4	WASHER	CS	WASHER: FLAT CS Ø0.50	-

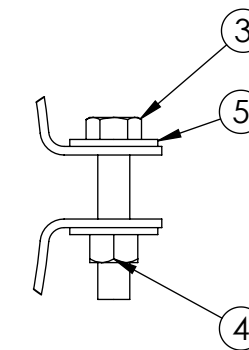

DETAIL A
SCALE 1 : 3

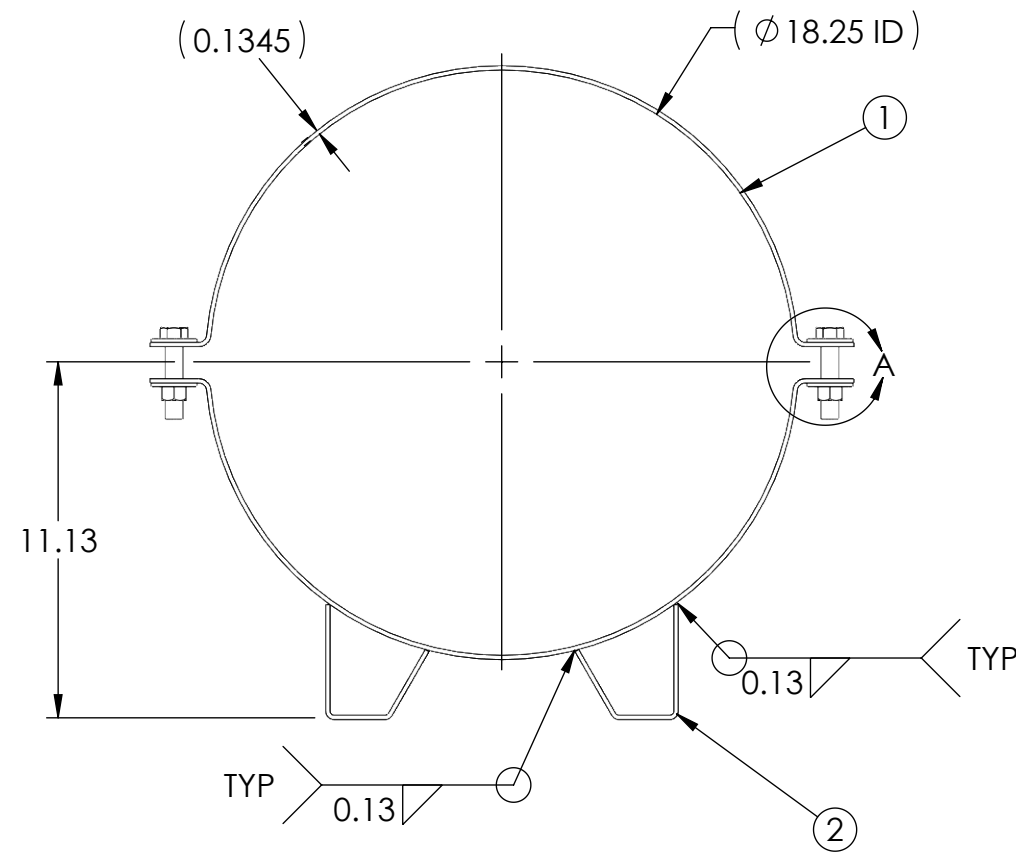
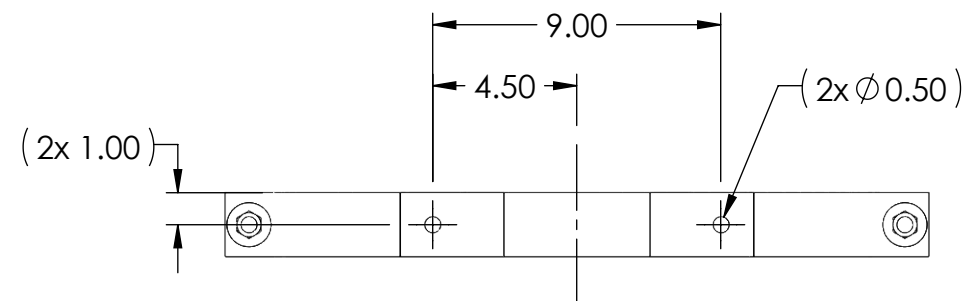
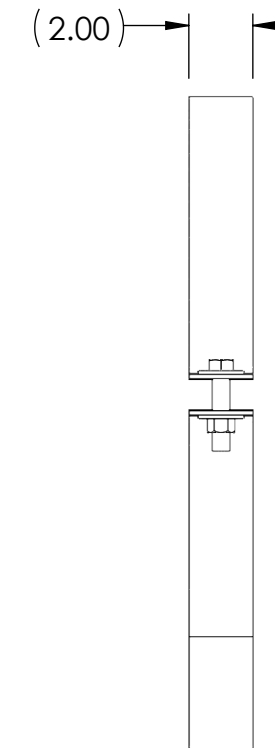

PROJECT NAME	
SALES ORDER NO.	
FABRICATION P.O.	

PROPRIETARY AND CONFIDENTIAL

THE INFORMATION CONTAINED IN THIS DRAWING IS THE SOLE PROPERTY OF MIRATECH GROUP, LLC. ANY REPRODUCTION IN PART OR AS A WHOLE WITHOUT THE WRITTEN PERMISSION OF MIRATECH GROUP, LLC IS PROHIBITED.

DIMENSIONAL TOLERANCES UNLESS OTHERWISE SPECIFIED
 ANGLES
 MACH: ±1° INCHES: ±0.125
 BEND: ±3° MILLIMETERS: ±2

DIMENSIONS ARE APPROXIMATE IN INCHES UNLESS OTHERWISE SPECIFIED

DO NOT SCALE DRAWING

DRAWN	DATE
CSF	06/28/2017

REVIEWED BY	DATE
CAC	06/28/2017

MFG APPR	DATE



**RMB2-18
Fabrication Drawing**

DRAWING	RMB2-18	REV	0
---------	---------	-----	---

SIZE	SCALE 1:4	WEIGHT: 5.28 lb	SHEET 1 OF 3
------	-----------	-----------------	--------------

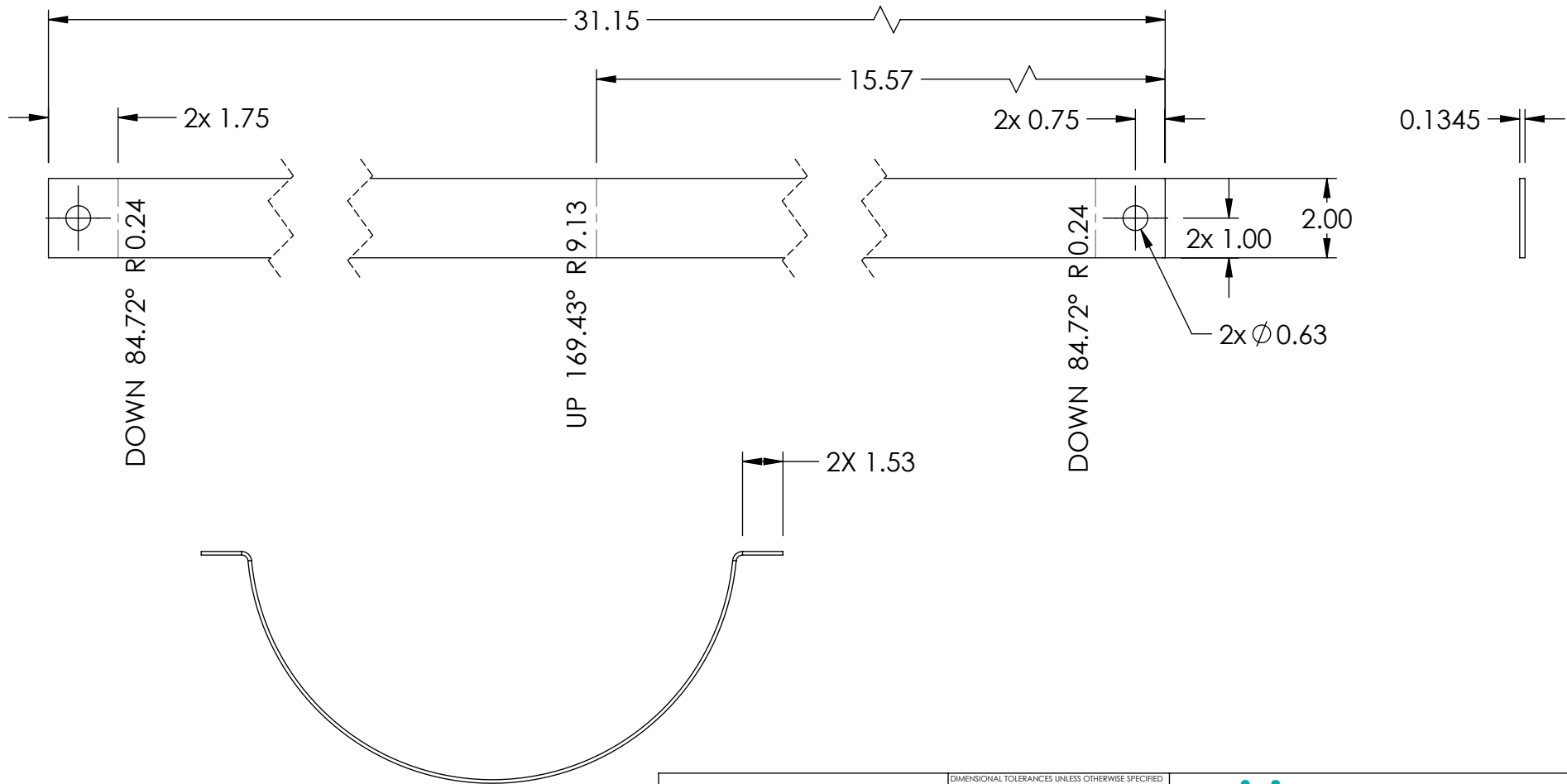

MATERIAL:
CS
DESCRIPTION:

SHEET: 10 GA

PROJECT NAME/CUSTOMER
SALES ORDER NO.
FABRICATION P.O.

PROPRIETARY AND CONFIDENTIAL

THE INFORMATION CONTAINED IN THIS DRAWING IS THE SOLE PROPERTY OF MIRATECH GROUP, LLC. ANY REPRODUCTION IN PART OR AS A WHOLE WITHOUT THE WRITTEN PERMISSION OF MIRATECH GROUP, LLC IS PROHIBITED.

SCALE 1:4

WEIGHT: 2.34 lb

SIZE
A

DIMENSIONAL TOLERANCES UNLESS OTHERWISE SPECIFIED

ANGLES: ±1°
MACH: ±0.125 INCHES
BEND: ±3° MILLIMETERS: ±2

DIMENSIONS ARE APPROXIMATE IN INCHES UNLESS OTHERWISE SPECIFIED

DO NOT SCALE DRAWING

DRAWN CSF	DATE 06/28/2017
ENG APPR CAC	DATE 06/28/2017
MFG APPR	DATE



**BAND
Part Detail**

ERP NUMBER 525110	ERP QUANTITY 61.792	REV 0
DRAWING RMB2-18		SHEET 2 OF 3

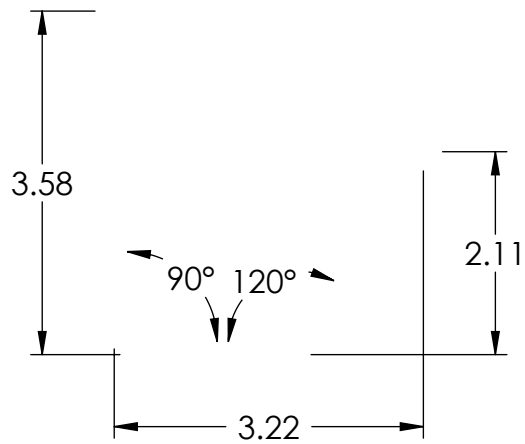
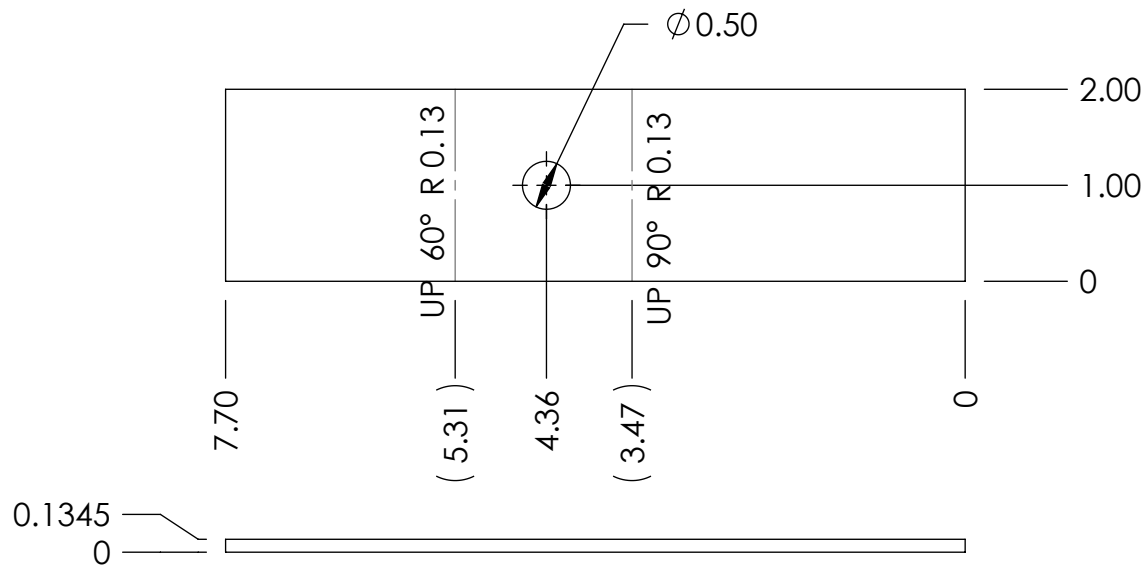

MATERIAL:
CS
DESCRIPTION:

SHEET:10 GA

PROJECT NAME/CUSTOMER
SALES ORDER NO.
FABRICATION P.O.

PROPRIETARY AND CONFIDENTIAL

THE INFORMATION CONTAINED IN THIS DRAWING IS THE SOLE PROPERTY OF MIRATECH GROUP, LLC. ANY REPRODUCTION IN PART OR AS A WHOLE WITHOUT THE WRITTEN PERMISSION OF MIRATECH GROUP, LLC IS PROHIBITED.

SCALE 1:2

WEIGHT: 0.00000 lb

SIZE
A

DIMENSIONAL TOLERANCES UNLESS OTHERWISE SPECIFIED

ANGLES: ±1°
MACH: ±0.015
BEND: ±3°

INCHES: ±0.125
MILLIMETERS: ±2

DIMENSIONS ARE APPROXIMATE IN INCHES UNLESS OTHERWISE SPECIFIED

DO NOT SCALE DRAWING

DRAWN CSF	DATE 06/28/2017
ENG APPR CAC	DATE 06/28/2017
MFG APPR	DATE



**FOOT
Part Detail**

ERP NUMBER 525110	ERP QUANTITY 15.408	REV 0
DRAWING RMB2-18		SHEET 3 OF 3