

REVISIONS				
REV.	DESCRIPTION	DATE	SHEET(S)	DRAWN BY
0	INITIAL RELEASE	11/04/2016	1	FES
1	CLEAN OUT WAS 1-1/2 NPT	12/11/2017	1	FES

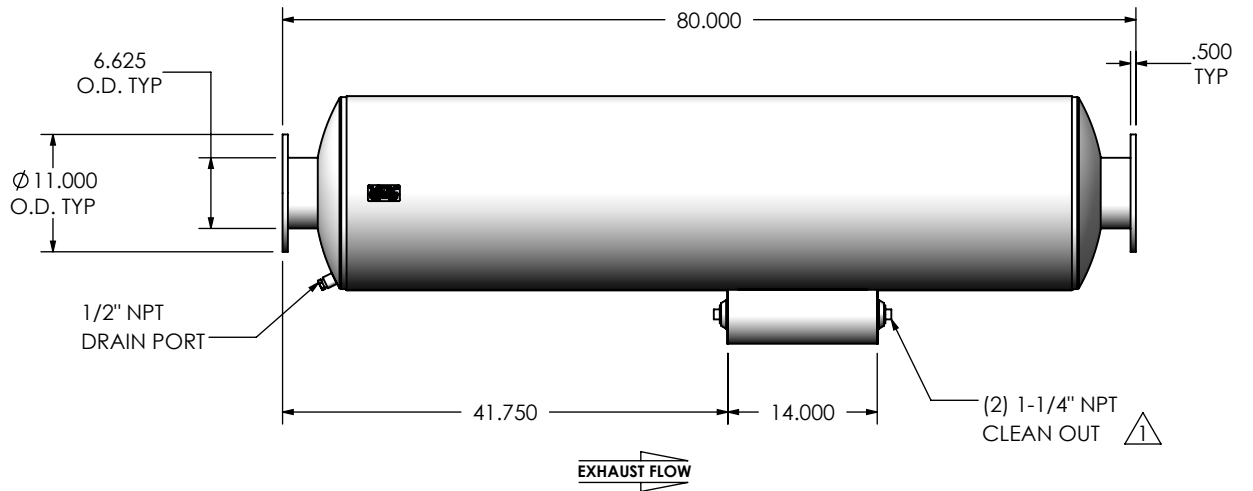
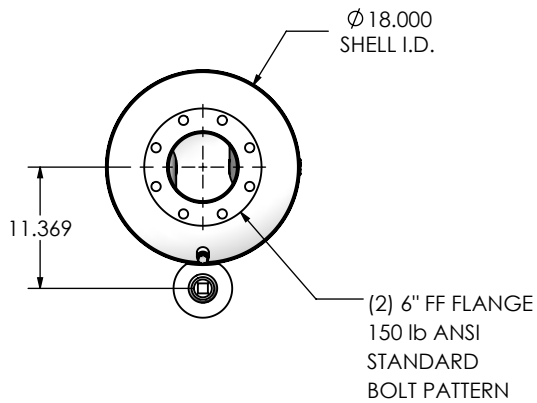
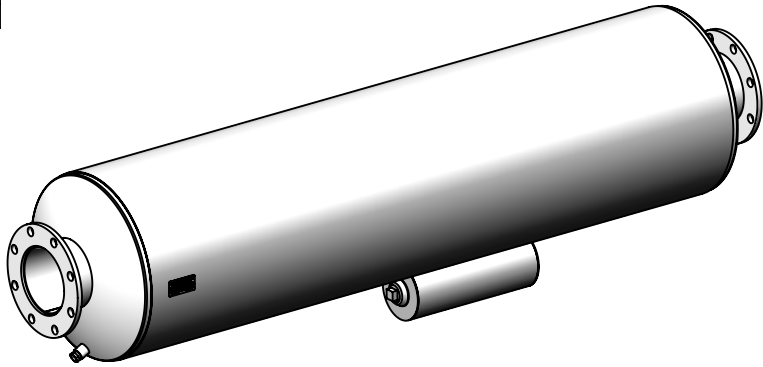

NOTES:

- DO NOT USE EQUIPMENT TO SUPPORT OTHER PARTS OF THE EXHAUST SYSTEM WITHOUT PROPER REINFORCEMENT

MATERIAL CONSTRUCTION:

- CARBON STEEL

PAINT:

- HIGH TEMPERATURE BLACK (MIRATECH COATING SYSTEM 5)

PROJECT NAME	<p>PROPRIETARY AND CONFIDENTIAL</p> <p>THE INFORMATION CONTAINED IN THIS DRAWING IS THE SOLE PROPERTY OF MIRATECH GROUP, LLC. ANY REPRODUCTION IN PART OR AS A WHOLE WITHOUT THE WRITTEN PERMISSION OF MIRATECH GROUP, LLC IS PROHIBITED.</p>
PROPOSAL NUMBER	
SALES ORDER NO.	
CUSTOMER P.O.	

<p>DIMENSIONS ARE IN INCHES UNLESS OTHERWISE SPECIFIED</p> <p>ANGLES: INCHES: ±0.125 MACH: ±1" MILLIMETERS: ±2 BEND: ±3"</p> <p>DO NOT SCALE DRAWING</p>	
DRAWN	DATE
FES	11/1/2016
REVIEWED BY	DATE
AJM	11/4/2016

DRAWING		REV
SUHEE0-06PF-2-00000000 SD		1
SIZE	SCALE	WEIGHT
A	1:18	187 lb

<p>SUHEE0-06PF-2-00000000 Sales Drawing</p>			
DRAWING		REV	
SUHEE0-06PF-2-00000000 SD		1	
SIZE	SCALE	WEIGHT	
A	1:18	187 lb	SHEET 1 OF 1