

REVISIONS				
REV.	DESCRIPTION	DATE	SHEET(S)	DRAWN BY
0	INITIAL RELEASE	11/04/2016	1	FES
1	CLEAN OUT WAS 1-1/2 NPT, DIM 29.694 WA 27.694	12/11/2017	1	FES

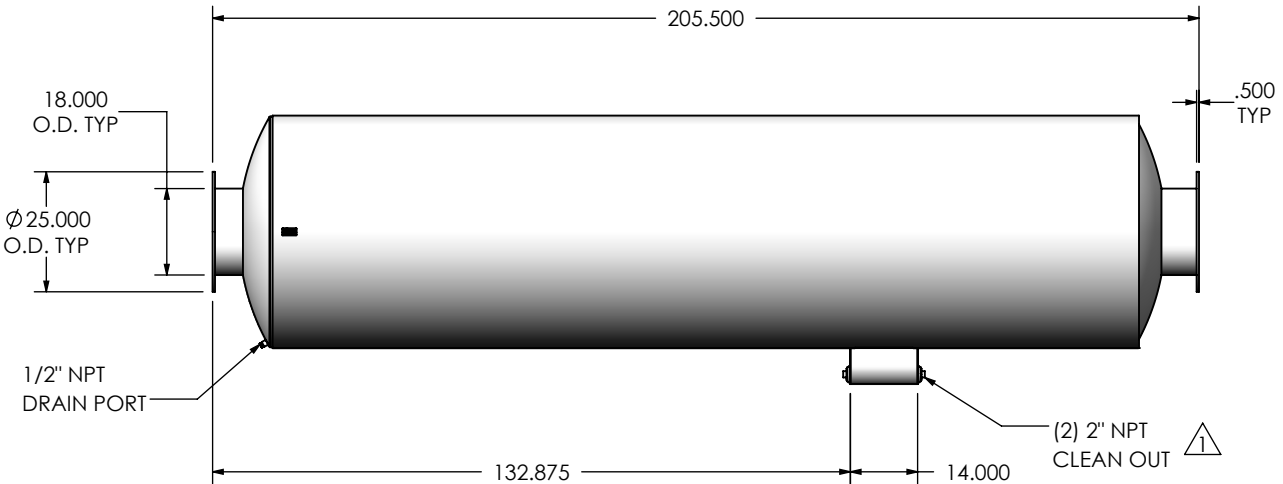
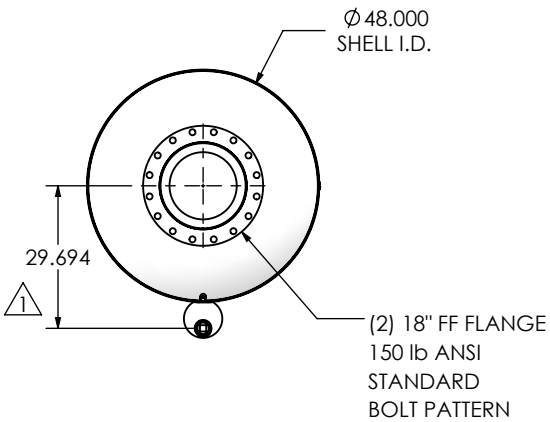
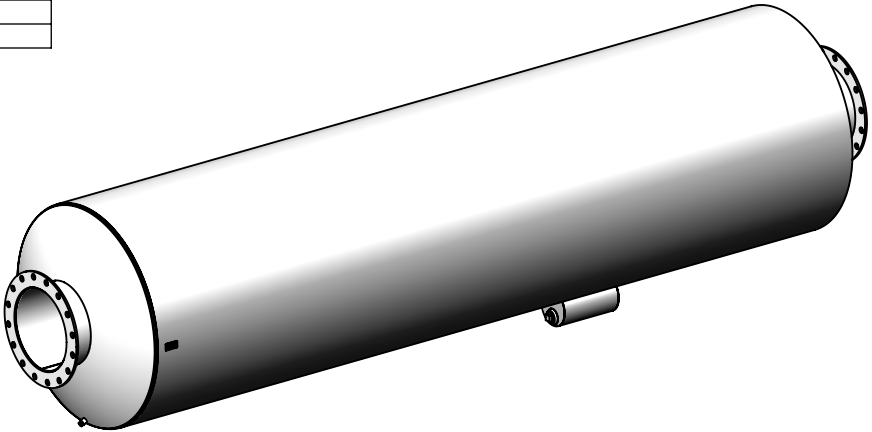

NOTES:

- DO NOT USE EQUIPMENT TO SUPPORT OTHER PARTS OF THE EXHAUST SYSTEM WITHOUT PROPER REINFORCEMENT

MATERIAL CONSTRUCTION:

- 304 STAINLESS STEEL

PAINT:

- NONE

PROJECT NAME	PROPRIETARY AND CONFIDENTIAL THE INFORMATION CONTAINED IN THIS DRAWING IS THE SOLE PROPERTY OF MIRATECH GROUP, LLC. ANY REPRODUCTION IN PART OR AS A WHOLE WITHOUT THE WRITTEN PERMISSION OF MIRATECH GROUP, LLC IS PROHIBITED.
PROPOSAL NUMBER	
SALES ORDER NO.	
CUSTOMER P.O.	

DIMENSIONS ARE IN INCHES UNLESS OTHERWISE SPECIFIED	
DIMENSIONAL TOLERANCES UNLESS OTHERWISE SPECIFIED ANGLES: MACH: ±1° BEND: ±3°	INCHES: ±0.125 MILLIMETERS: ±2
DO NOT SCALE DRAWING	
DRAWN	DATE
FES	11/1/2016
REVIEWED BY	DATE
AJM	11/4/2016



SUHEE0-18PF-3-00000000
Sales Drawing

DRAWING		SUHEE0-18PF-3-00000000 SD		REV
SIZE		SCALE 1:40		1
A	WEIGHT: 2410 lb	SHEET 1 OF 1		