

REVISIONS				
REV.	DESCRIPTION	DATE	SHEET(S)	DRAWN BY
0	INITIAL RELEASE	11/04/2016	1	FES
1	CLEAN OUT WAS 1-1/2 NPT, DIM 35.711 WAS 33.711	12/11/2017	1	FES

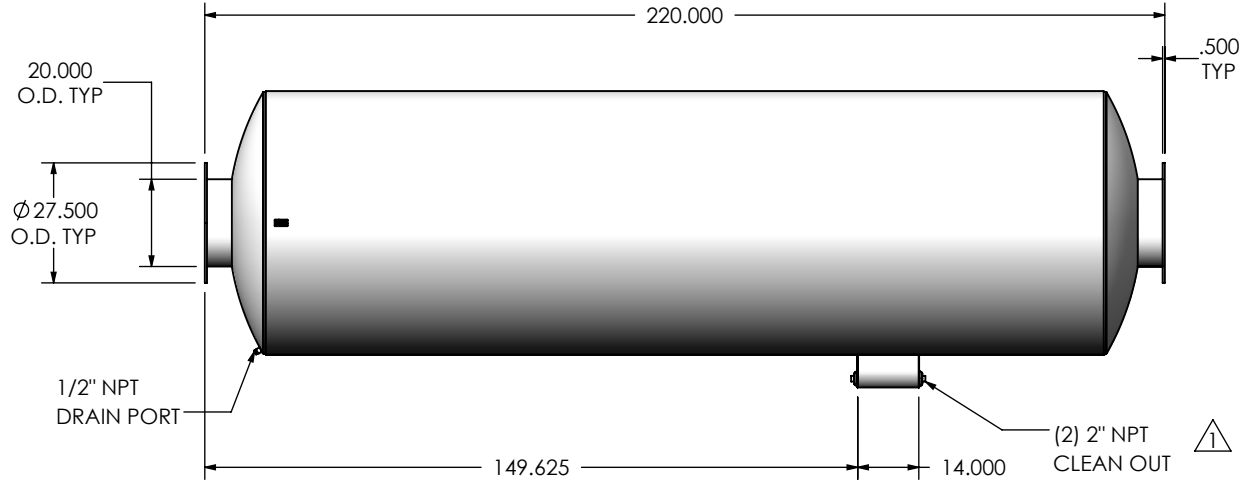

**NOTES:**

- DO NOT USE EQUIPMENT TO SUPPORT OTHER PARTS OF THE EXHAUST SYSTEM WITHOUT PROPER REINFORCEMENT

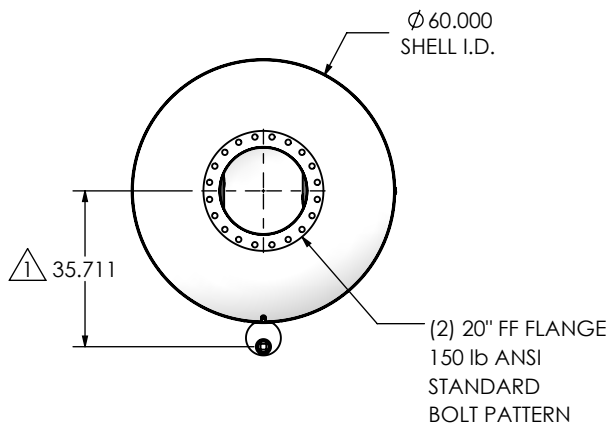
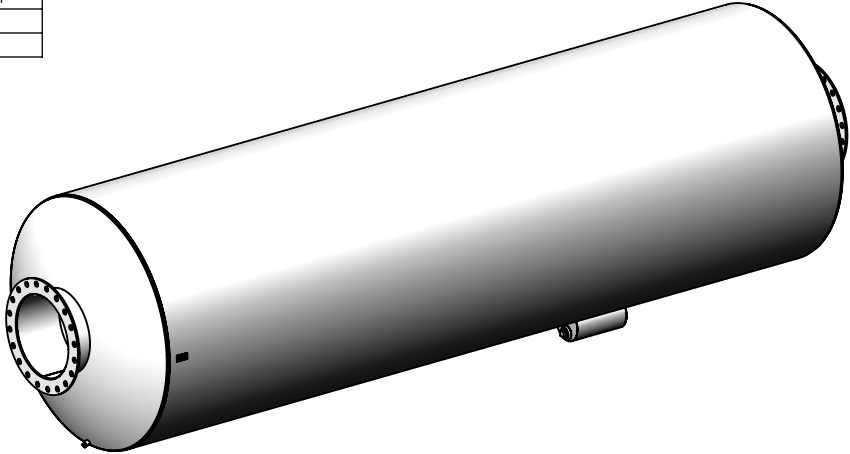

**MATERIAL CONSTRUCTION:**

- CARBON STEEL

**PAINT:**

- HIGH TEMPERATURE BLACK (MIRATECH COATING SYSTEM 5)



PROJECT NAME	<b>PROPRIETARY AND CONFIDENTIAL</b>  THE INFORMATION CONTAINED IN THIS DRAWING IS THE SOLE PROPERTY OF MIRATECH GROUP, LLC. ANY REPRODUCTION IN PART OR AS A WHOLE WITHOUT THE WRITTEN PERMISSION OF MIRATECH GROUP, LLC IS PROHIBITED.	DIMENSIONS ARE IN INCHES UNLESS OTHERWISE SPECIFIED <small>           DIMENSIONAL TOLERANCES UNLESS OTHERWISE SPECIFIED            ANGLES: MACH: <math>\pm 1^\circ</math> INCHES: <math>\pm 0.125</math>            BEND: <math>\pm 3^\circ</math> MILLIMETERS: <math>\pm 2</math> </small>		 			
PROPOSAL NUMBER		DO NOT SCALE DRAWING		<b>SUHEE0-20PF-2-00000000</b> <b>Sales Drawing</b>			
SALES ORDER NO.		DRAWN	DATE	DRAWING		REV	
CUSTOMER P.O.		FES	11/1/2016	SUHEE0-20PF-2-00000000 SD		1	
		REVIEWED BY	DATE	SIZE	SCALE	WEIGHT	SHEET
		AJM	11/4/2016	A	SCALE 1:44	WEIGHT: 3142 lb	1 OF 1