

REVISIONS				
REV.	DESCRIPTION	DATE	SHEET(S)	DRAWN BY
0	INITIAL RELEASE	11/04/2016	1	FES
1	CLEAN OUT WAS 1-1/2", DIM 35.711 WAS 33.711	12/11/2017	1	FES

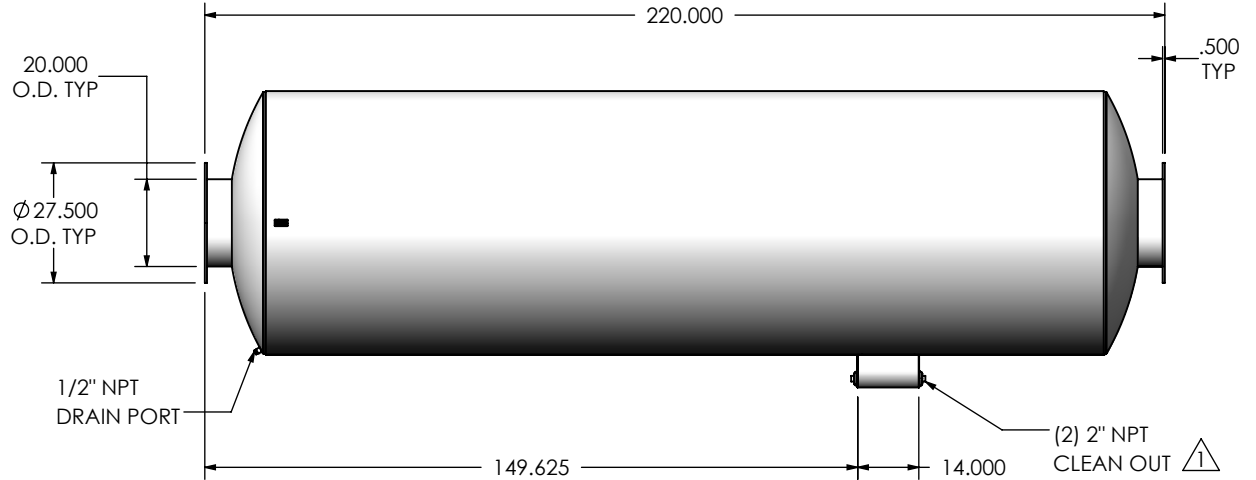

**NOTES:**

- DO NOT USE EQUIPMENT TO SUPPORT OTHER PARTS OF THE EXHAUST SYSTEM WITHOUT PROPER REINFORCEMENT

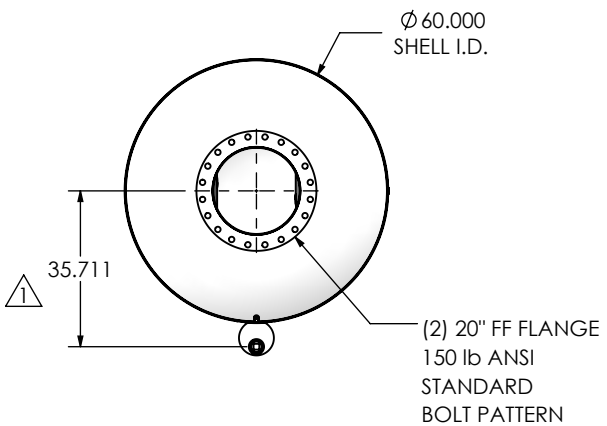
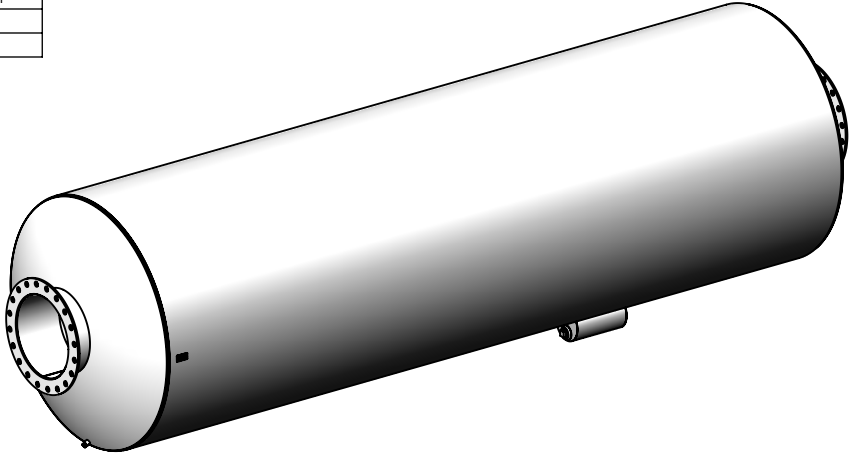

**MATERIAL CONSTRUCTION:**

- 304 STAINLESS STEEL

**PAINT:**

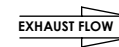
- NONE



PROJECT NAME	<p><b>PROPRIETARY AND CONFIDENTIAL</b></p> <p>THE INFORMATION CONTAINED IN THIS DRAWING IS THE SOLE PROPERTY OF MIRATECH GROUP, LLC. ANY REPRODUCTION IN PART OR AS A WHOLE WITHOUT THE WRITTEN PERMISSION OF MIRATECH GROUP, LLC IS PROHIBITED.</p>	DIMENSIONS ARE IN INCHES UNLESS OTHERWISE SPECIFIED <small>ANGLES</small> MACH: ±1°    INCHES: ±0.125 BEND: ±3°    MILLIMETERS: ±2		 			
PROPOSAL NUMBER		DO NOT SCALE DRAWING		<b>SUHEE0-20PF-3-00000000</b> <b>Sales Drawing</b>			
SALES ORDER NO.		DRAWN	DATE	DRAWING		REV	
CUSTOMER P.O.		FES	11/1/2016	SUHEE0-20PF-3-00000000 SD		1	
		REVIEWED BY	DATE	SIZE	SCALE	WEIGHT	SHEET
		AJM	11/4/2016	A	SCALE 1:44	WEIGHT: 3221 lb	1 OF 1