

REVISIONS				
REV.	DESCRIPTION	DATE	SHEET(S)	DRAWN BY
0	INITIAL RELEASE	11/04/2016	1	FES
1	CLEAN OUT WAS 1-1/2 NPT	12/11/2017	1	FES

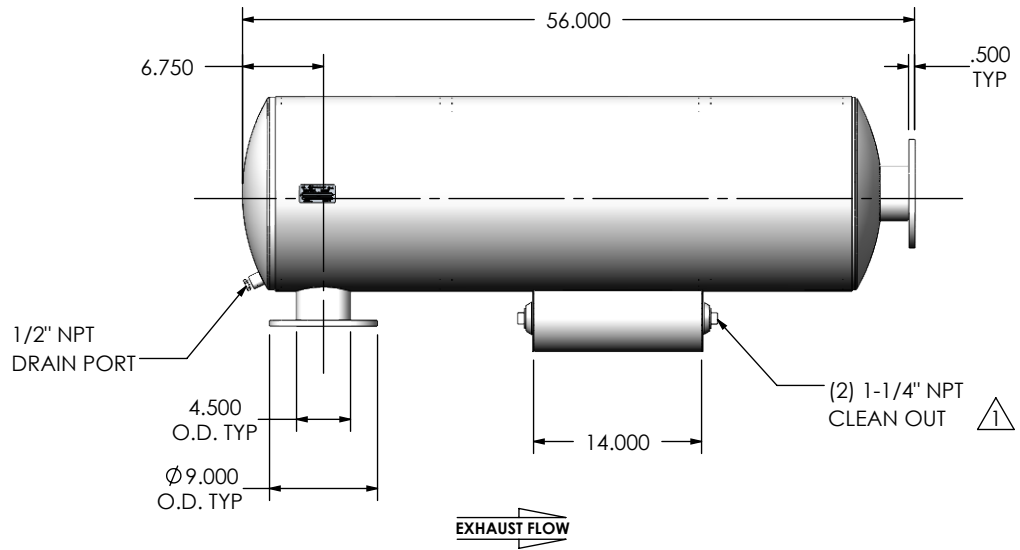
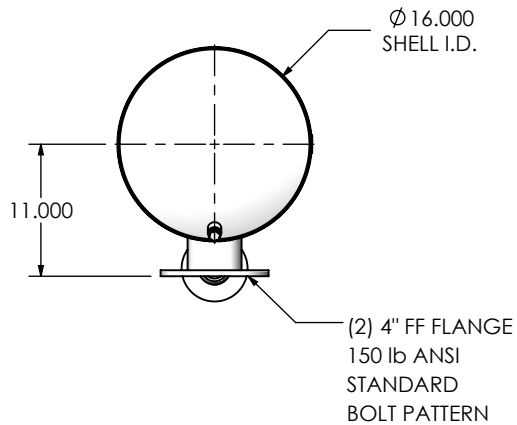
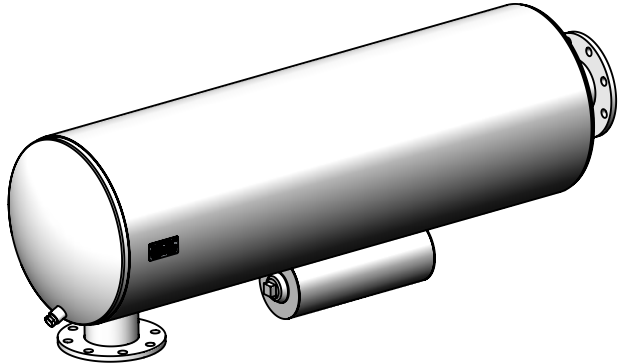

NOTES:

- DO NOT USE EQUIPMENT TO SUPPORT OTHER PARTS OF THE EXHAUST SYSTEM WITHOUT PROPER REINFORCEMENT

MATERIAL CONSTRUCTION:



- 304 STAINLESS STEEL

PAINT:

- NONE

PROJECT NAME	PROPRIETARY AND CONFIDENTIAL THE INFORMATION CONTAINED IN THIS DRAWING IS THE SOLE PROPERTY OF MIRATECH GROUP, LLC. ANY REPRODUCTION IN PART OR AS A WHOLE WITHOUT THE WRITTEN PERMISSION OF MIRATECH GROUP, LLC IS PROHIBITED.
PROPOSAL NUMBER	
SALES ORDER NO.	
CUSTOMER P.O.	

DIMENSIONS ARE IN INCHES UNLESS OTHERWISE SPECIFIED <small>DIMENSIONAL TOLERANCES UNLESS OTHERWISE SPECIFIED</small> ANGLES: MACH: $\pm 1^\circ$ INCHES: ± 0.125 BEND: $\pm 3^\circ$ MILLIMETERS: ± 2	
DO NOT SCALE DRAWING	
DRAWN FES	DATE 11/1/2016
REVIEWED BY AJM	DATE 11/4/2016

 	
SUHGE0-04PF-3-0000001Y Sales Drawing	
DRAWING	
SUHGE0-04PF-3-0000001Y SD	
REV 1	
SIZE A	SCALE 1:16
WEIGHT: 126 lb	SHEET 1 OF 1