

REVISIONS				
REV.	DESCRIPTION	DATE	SHEET(S)	DRAWN BY
0	ORIGINAL RELEASE	08/15/2016	1	JFS
1	(2) 1-1/4" NPT CLEAN OUT WAS (2) 1-1/2" NPT CLEAN OUT	12/12/2017	1	MAM

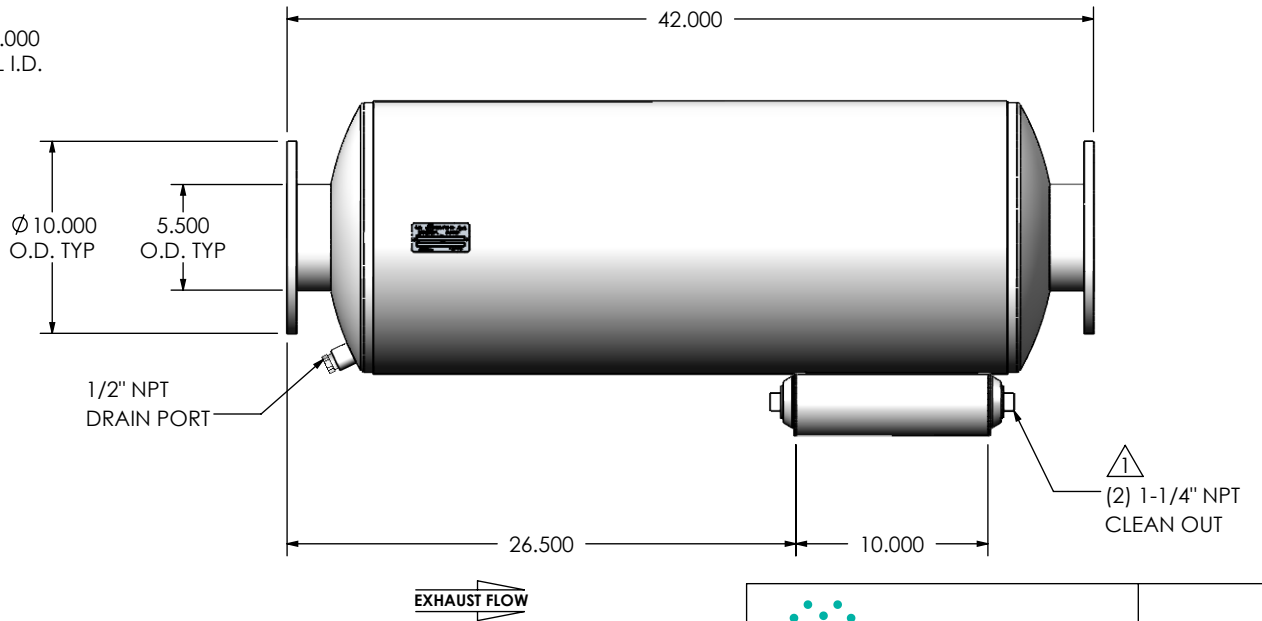
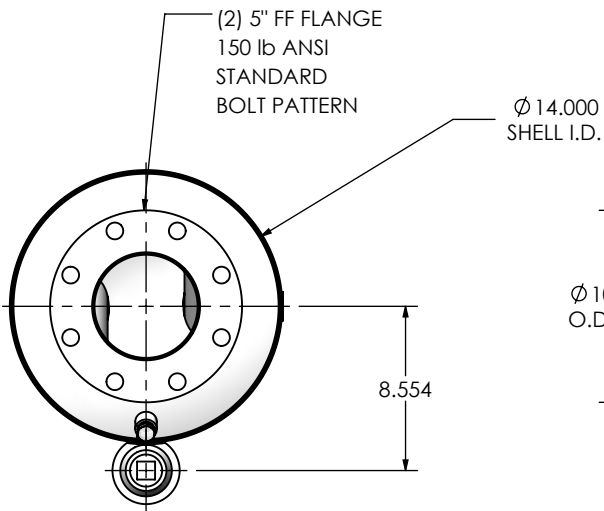
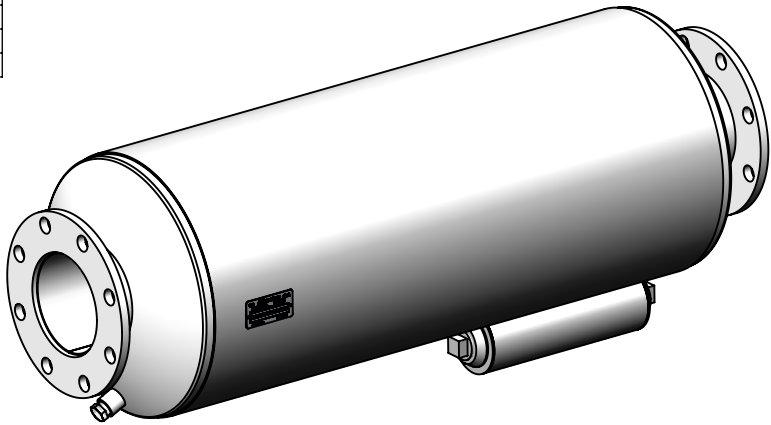

NOTES:

- DO NOT USE EQUIPMENT TO SUPPORT OTHER PARTS OF THE EXHAUST SYSTEM WITHOUT PROPER REINFORCEMENT

MATERIAL CONSTRUCTION:

- ALUMINIZED STEEL

PAINT:

- HIGH TEMPERATURE BLACK (MIRATECH COATING SYSTEM 5)

PROJECT NAME
PROPOSAL NUMBER
SALES ORDER NO.
CUSTOMER P.O.

PROPRIETARY AND CONFIDENTIAL

THE INFORMATION CONTAINED IN THIS DRAWING IS THE SOLE PROPERTY OF MIRATECH GROUP, LLC. ANY REPRODUCTION IN PART OR AS A WHOLE WITHOUT THE WRITTEN PERMISSION OF MIRATECH GROUP, LLC IS PROHIBITED.

DIMENSIONS ARE IN INCHES UNLESS OTHERWISE SPECIFIED			
DIMENSIONAL TOLERANCES UNLESS OTHERWISE SPECIFIED			
ANGLES:			
MACH: ±1"	INCHES: ±0.125		
BEND: ±3"	MILLIMETERS: ±2		
DO NOT SCALE DRAWING			
DRAWN	JFS	DATE	08/15/2016
REVIEWED BY	EQJ	DATE	08/15/2016

SUIEE0-05PF-1-00000000 Sales Drawing			
DRAWING		SUIEE0-05PF-1-00000000 SD	
REV	1	SCALE	1:10
SIZE	A	WEIGHT	75 lb
		SHEET 1 OF 1	