

REVISIONS				
REV.	DESCRIPTION	DATE	SHEET(S)	DRAWN BY
0	ORIGINAL RELEASE	08/15/2016	1	JFS
1	(2) 1-1/4" NPT CLEAN OUT WAS (2) 1-1/2" NPT CLEAN OUT	12/12/2017	1	MAM

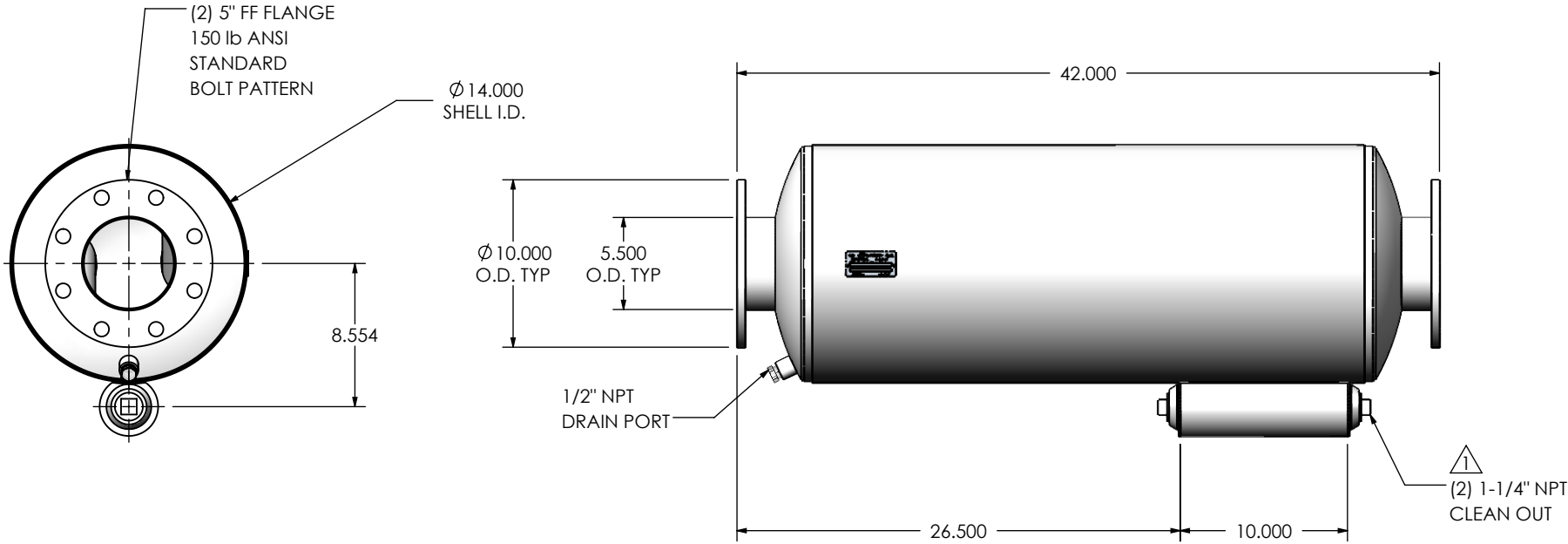
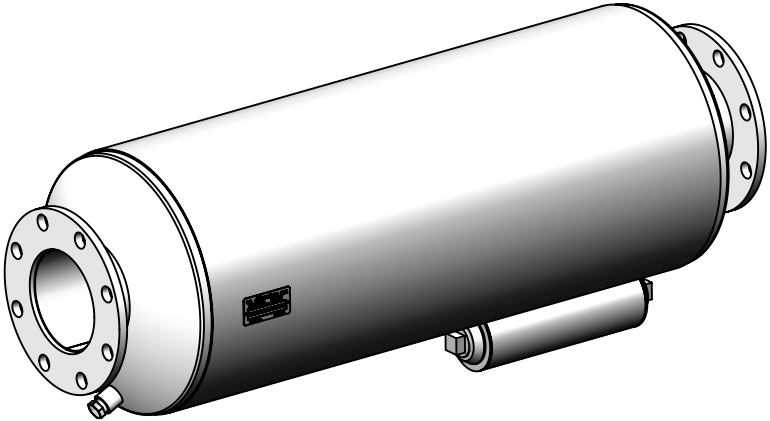

NOTES:

- DO NOT USE EQUIPMENT TO SUPPORT OTHER PARTS OF THE EXHAUST SYSTEM WITHOUT PROPER REINFORCEMENT

MATERIAL CONSTRUCTION:

- 304 STAINLESS STEEL

PAINT:

- NONE



PROJECT NAME	
PROPOSAL NUMBER	
SALES ORDER NO.	
CUSTOMER P.O.	

PROPRIETARY AND CONFIDENTIAL

THE INFORMATION CONTAINED IN THIS DRAWING IS THE SOLE PROPERTY OF MIRATECH GROUP, LLC. ANY REPRODUCTION IN PART OR AS A WHOLE WITHOUT THE WRITTEN PERMISSION OF MIRATECH GROUP, LLC IS PROHIBITED.

DIMENSIONS ARE IN INCHES UNLESS OTHERWISE SPECIFIED	
DIMENSIONAL TOLERANCES UNLESS OTHERWISE SPECIFIED	
ANGLES:	
MACH: $\pm 1^{\circ}$	INCHES: ± 0.125
BEND: $\pm 3^{\circ}$	MILLIMETERS: ± 2
DO NOT SCALE DRAWING	
DRAWN	DATE
JFS	08/15/2016
REVIEWED BY	DATE
EQJ	08/15/2016

SUIEE0-05PF-3-00000000 Sales Drawing			
DRAWING		SUIEE0-05PF-3-00000000 SD	
REV	1	SCALE	1:10
SIZE	A	WEIGHT	77 lb
		SHEET 1 OF 1	