

REVISIONS				
REV.	DESCRIPTION	DATE	SHEET(S)	DRAWN BY
0	ORIGINAL RELEASE	08/15/2016	1	JFS
1	(2) 2" NPT CLEAN OUT WAS (2) 1-1/2" NPT CLEAN OUT, 32.703 WAS 30.703	12/12/2017	1	MAM

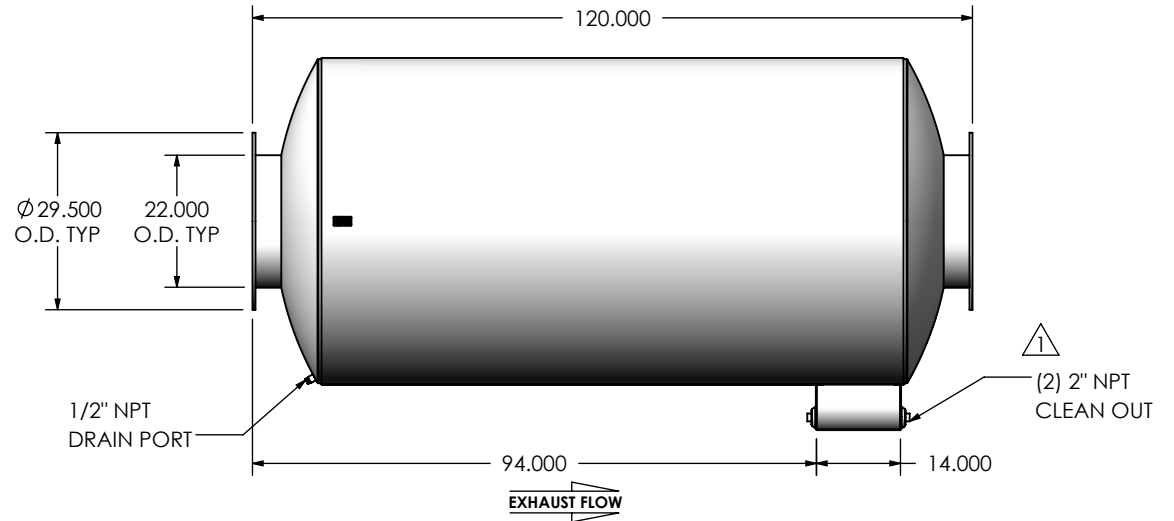
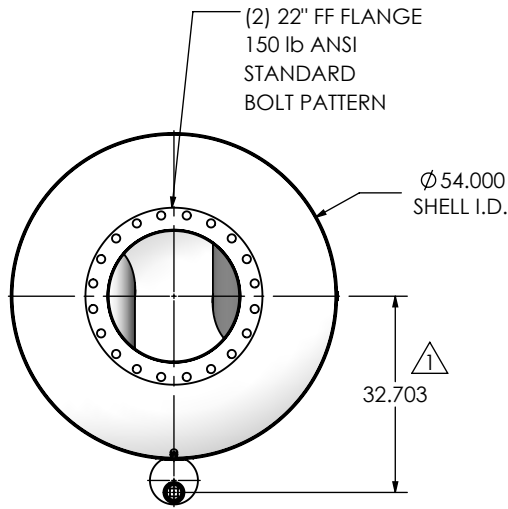
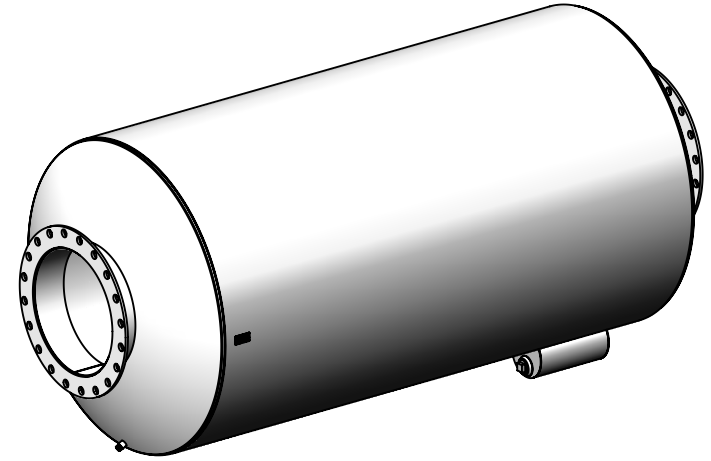

NOTES:

- DO NOT USE EQUIPMENT TO SUPPORT OTHER PARTS OF THE EXHAUST SYSTEM WITHOUT PROPER REINFORCEMENT

MATERIAL CONSTRUCTION:

- CARBON STEEL

PAINT:

- HIGH TEMPERATURE BLACK (MIRATECH COATING SYSTEM 5)

PROJECT NAME	
PROPOSAL NUMBER	
SALES ORDER NO.	
CUSTOMER P.O.	

PROPRIETARY AND CONFIDENTIAL

THE INFORMATION CONTAINED IN THIS DRAWING IS THE SOLE PROPERTY OF MIRATECH GROUP, LLC. ANY REPRODUCTION IN PART OR AS A WHOLE WITHOUT THE WRITTEN PERMISSION OF MIRATECH GROUP, LLC IS PROHIBITED.

DIMENSIONS ARE IN INCHES UNLESS OTHERWISE SPECIFIED

DIMENSIONAL TOLERANCES UNLESS OTHERWISE SPECIFIED	
ANGLES	
MACH: ±1"	INCHES: ±0.125
BEND: ±3"	MILLIMETERS: ±2

DO NOT SCALE DRAWING

DRAWN	DATE
JFS	08/15/2016
REVIEWED BY	DATE
EQJ	08/15/2016



SUIEE0-22PF-2-00000000
Sales Drawing

DRAWING		SUIEE0-22PF-2-00000000 SD		REV
				1
SIZE	SCALE	WEIGHT	SHEET	
A	1:32	1597 lb	1 OF 1	