

REVISIONS				
REV.	DESCRIPTION	DATE	SHEET(S)	DRAWN BY
0	ORIGINAL RELEASE	08/15/2016	1	JFS
1	(2) 1-1/4" NPT CLEAN OUT WAS (2) 1-1/2" NPT CLEAN OUT	12/13/2017	1	MAM

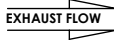
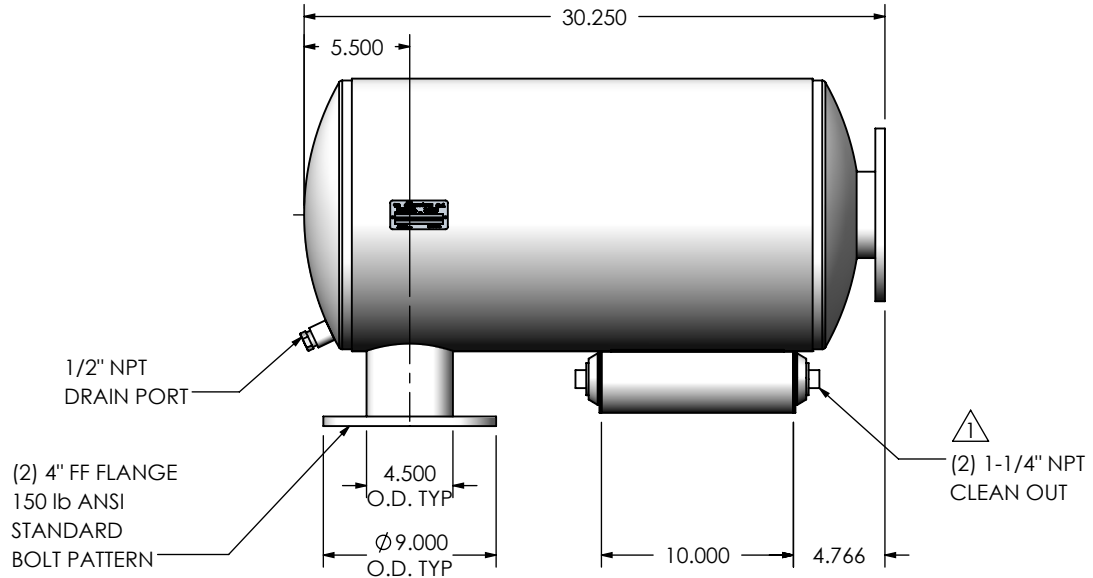
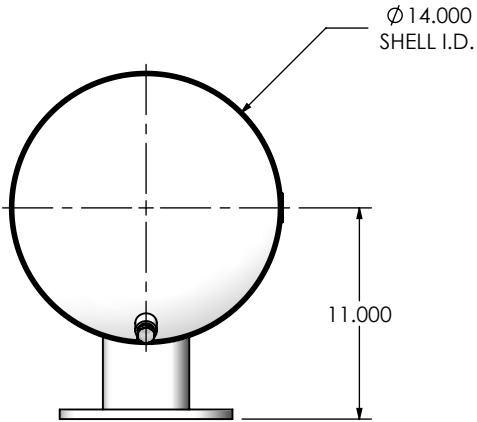
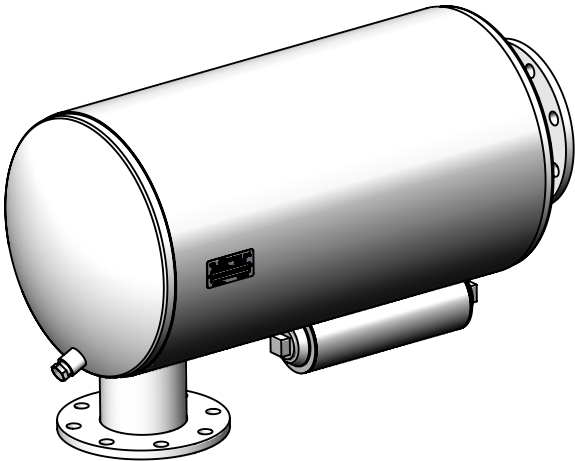

NOTES:

- DO NOT USE EQUIPMENT TO SUPPORT OTHER PARTS OF THE EXHAUST SYSTEM WITHOUT PROPER REINFORCEMENT

MATERIAL CONSTRUCTION:

- CARBON STEEL

PAINT:

- HIGH TEMPERATURE BLACK (MIRATECH COATING SYSTEM 5)

PROJECT NAME	PROPRIETARY AND CONFIDENTIAL THE INFORMATION CONTAINED IN THIS DRAWING IS THE SOLE PROPERTY OF MIRATECH GROUP, LLC. ANY REPRODUCTION IN PART OR AS A WHOLE WITHOUT THE WRITTEN PERMISSION OF MIRATECH GROUP, LLC IS PROHIBITED.	DIMENSIONS ARE IN INCHES UNLESS OTHERWISE SPECIFIED <small>DIMENSIONAL TOLERANCES UNLESS OTHERWISE SPECIFIED</small> ANGLES: MACH: ±1° INCHES: ±0.125 BEND: ±3° MILLIMETERS: ±2					
PROPOSAL NUMBER		DO NOT SCALE DRAWING		SUIGE0-04PF-2-000001K Sales Drawing			
SALES ORDER NO.		DRAWN	DATE	DRAWING		REV	
CUSTOMER P.O.		JFS	08/15/2016	SUIGE0-04PF-2-000001K SD		1	
		REVIEWED BY	DATE	SIZE	SCALE	WEIGHT	SHEET
		EQJ	08/15/2016	A	1:10	63 lb	1 OF 1