

REVISIONS				
REV.	DESCRIPTION	DATE	SHEET(S)	DRAWN BY
0	ORIGINAL RELEASE	08/15/2016	1	JFS
1	(2) 2" NPT CLEAN OUT WAS (2) 1-1/2" NPT CLEAN OUT	12/12/2017	1	MAM

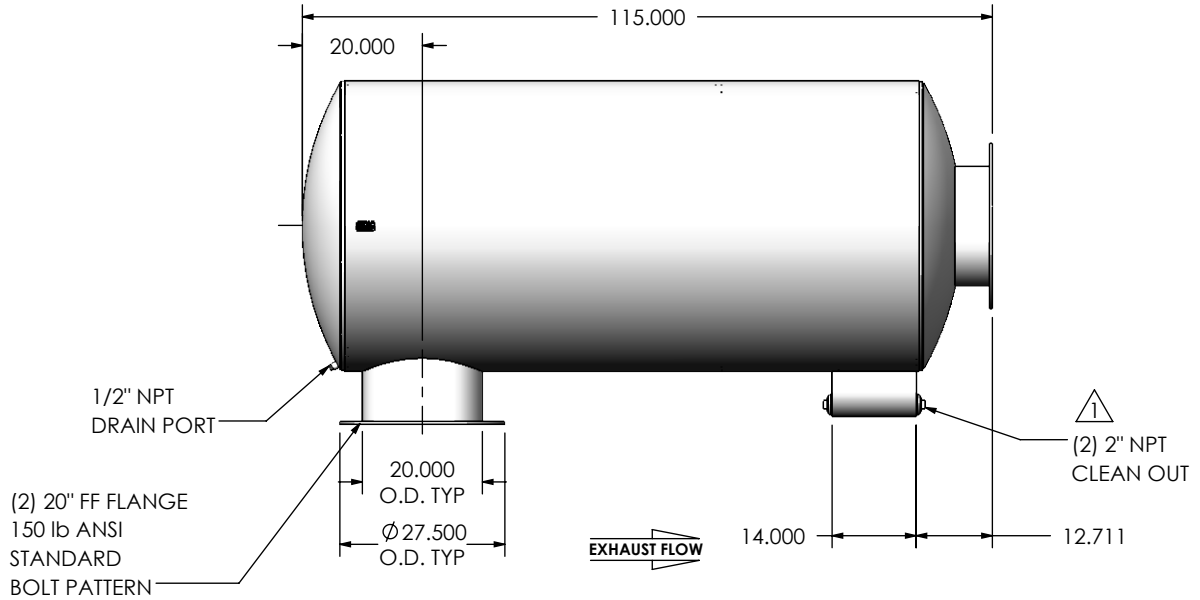

NOTES:

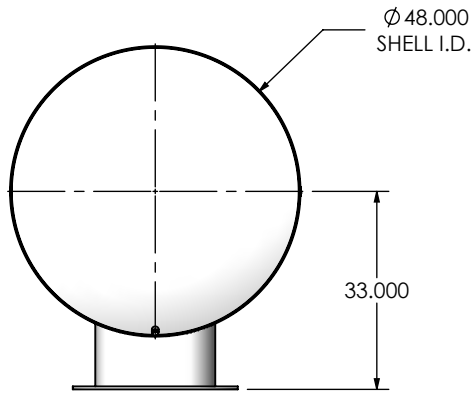
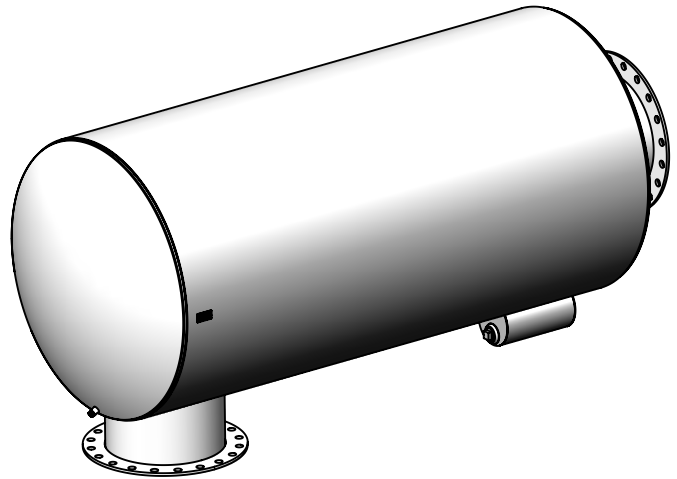

- DO NOT USE EQUIPMENT TO SUPPORT OTHER PARTS OF THE EXHAUST SYSTEM WITHOUT PROPER REINFORCEMENT

MATERIAL CONSTRUCTION:

- CARBON STEEL

PAINT:

- HIGH TEMPERATURE BLACK (MIRATECH COATING SYSTEM 5)

PROJECT NAME	<p align="center">PROPRIETARY AND CONFIDENTIAL</p> <p>THE INFORMATION CONTAINED IN THIS DRAWING IS THE SOLE PROPERTY OF MIRATECH GROUP, LLC. ANY REPRODUCTION IN PART OR AS A WHOLE WITHOUT THE WRITTEN PERMISSION OF MIRATECH GROUP, LLC IS PROHIBITED.</p>	DIMENSIONS ARE IN INCHES UNLESS OTHERWISE SPECIFIED <small>DIMENSIONAL TOLERANCES UNLESS OTHERWISE SPECIFIED</small> ANGLES: MACH: ±1° INCHES: ±0.125 BEND: ±3° MILLIMETERS: ±2		 			
PROPOSAL NUMBER		DO NOT SCALE DRAWING		SUIGE0-20PF-2-000005Q Sales Drawing			
SALES ORDER NO.		DRAWN	DATE	DRAWING		REV	
CUSTOMER P.O.		JFS	08/15/2016	SUIGE0-20PF-2-000005Q SD		1	
		REVIEWED BY	DATE	SIZE	SCALE	WEIGHT	SHEET
		EQJ	08/15/2016	A	1:32	1327 lb	1 OF 1