

REVISIONS				
REV.	DESCRIPTION	DATE	SHEET(S)	DRAWN BY
0	INITIAL RELEASE	8/26/2016	1	FES
1	CLEAN OUT WAS 1-1/2 NPT	12/18/2017	1	FES

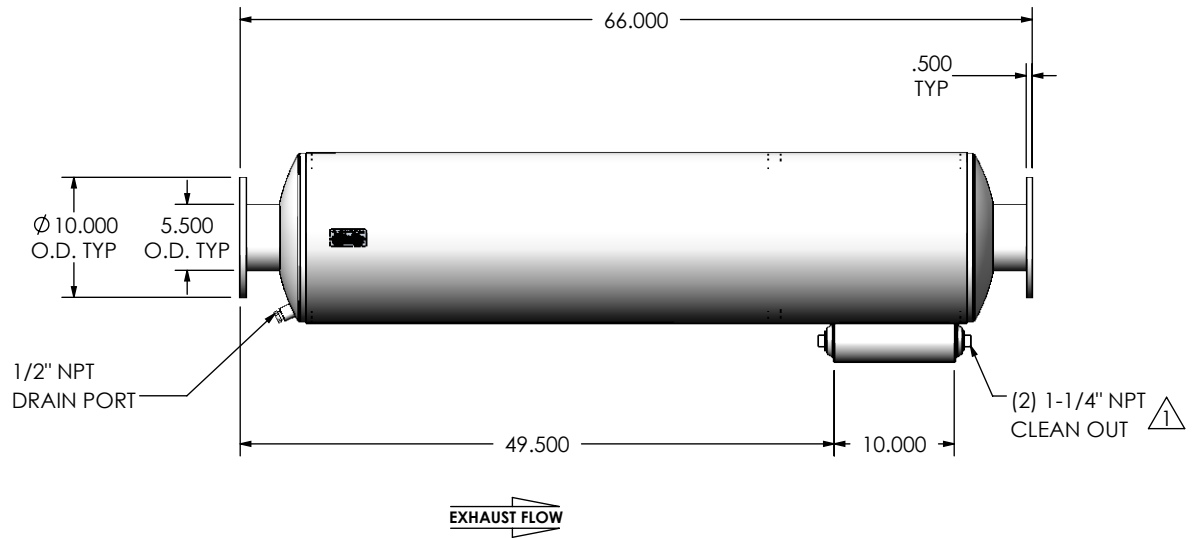
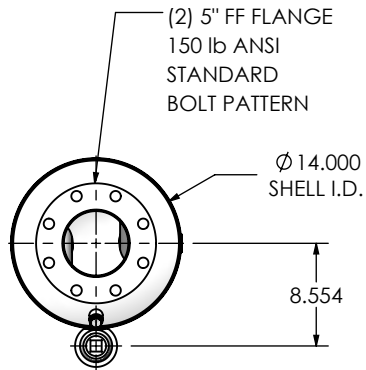
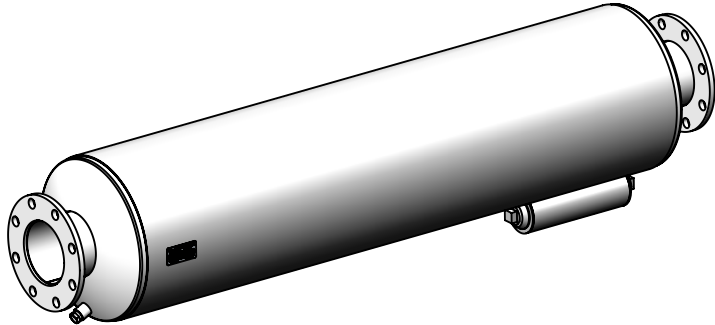

NOTES:

- DO NOT USE EQUIPMENT TO SUPPORT OTHER PARTS OF THE EXHAUST SYSTEM WITHOUT PROPER REINFORCEMENT

MATERIAL CONSTRUCTION:

- 304 STAINLESS STEEL

PAINT:

- NONE

PROJECT NAME	PROPRIETARY AND CONFIDENTIAL THE INFORMATION CONTAINED IN THIS DRAWING IS THE SOLE PROPERTY OF MIRATECH GROUP, LLC. ANY REPRODUCTION IN PART OR AS A WHOLE WITHOUT THE WRITTEN PERMISSION OF MIRATECH GROUP, LLC IS PROHIBITED.
PROPOSAL NUMBER	
SALES ORDER NO.	
CUSTOMER P.O.	

DIMENSIONS ARE IN INCHES UNLESS OTHERWISE SPECIFIED	
<small>DIMENSIONAL TOLERANCES UNLESS OTHERWISE SPECIFIED</small> ANGLES: MACH: ±1° INCHES: ±0.125 BEND: ±3° MILLIMETERS: ±2	
DO NOT SCALE DRAWING	
DRAWN	DATE
JFS	08/26/2016
REVIEWED BY	DATE
	08/15/2016

SUREE0-05PF-3-00000000 Sales Drawing			
DRAWING		REV	
SUREE0-05PF-3-00000000 SD		1	
SIZE	SCALE 1:16	WEIGHT: 104 lb	SHEET 1 OF 1
A			