

REVISIONS				
REV.	DESCRIPTION	DATE	SHEET(S)	DRAWN BY
0	INITIAL RELEASE	8/26/2016	1	FES
1	CLEAN OUT WAS 1-1/2 NPT	12/18/2017	1	FES

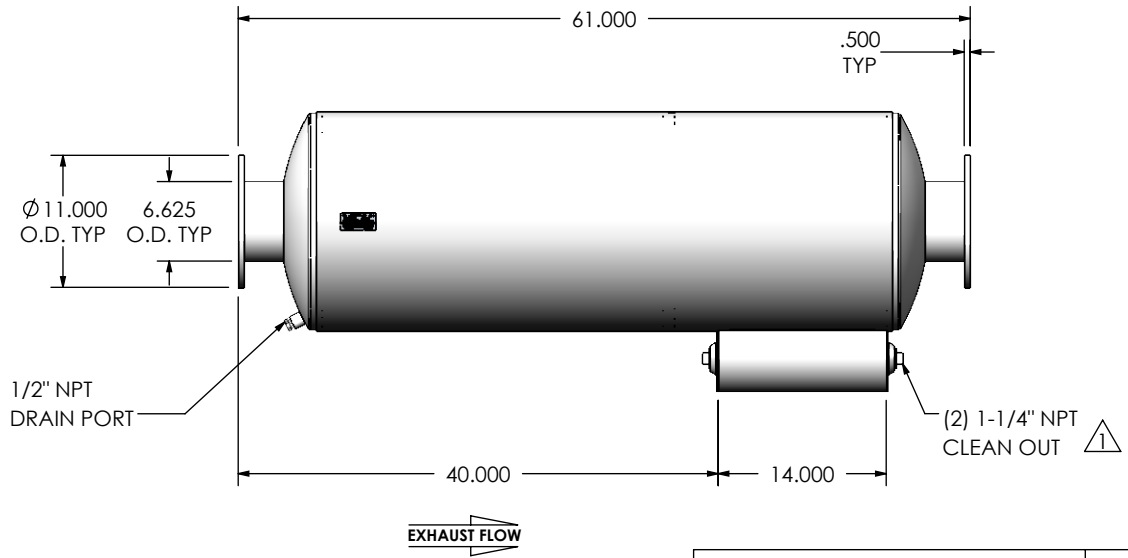
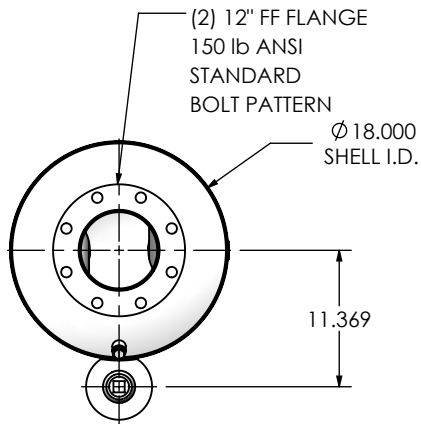
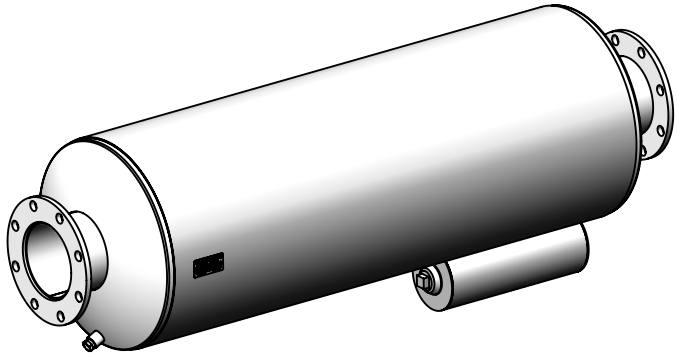

NOTES:

- DO NOT USE EQUIPMENT TO SUPPORT OTHER PARTS OF THE EXHAUST SYSTEM WITHOUT PROPER REINFORCEMENT

MATERIAL CONSTRUCTION:

- CARBON STEEL

PAINT:

- HIGH TEMPERATURE BLACK (MIRATECH COATING SYSTEM-5)

PROJECT NAME	
PROPOSAL NUMBER	
SALES ORDER NO.	
CUSTOMER P.O.	

PROPRIETARY AND CONFIDENTIAL

THE INFORMATION CONTAINED IN THIS DRAWING IS THE SOLE PROPERTY OF MIRATECH GROUP, LLC. ANY REPRODUCTION IN PART OR AS A WHOLE WITHOUT THE WRITTEN PERMISSION OF MIRATECH GROUP, LLC IS PROHIBITED.

DIMENSIONS ARE IN INCHES UNLESS OTHERWISE SPECIFIED	
DIMENSIONAL TOLERANCES UNLESS OTHERWISE SPECIFIED	
ANGLES:	
MACH: ±1"	INCHES: ±0.125
BEND: ±3"	MILLIMETERS: ±2
DO NOT SCALE DRAWING	
DRAWN	DATE
JFS	08/26/2016
REVIEWED BY	DATE
	08/15/2016

SUREE0-06PF-2-00000000 Sales Drawing			
DRAWING		SUREE0-06PF-2-00000000 SD	
REV	1	SCALE	1:16
SIZE	A	WEIGHT	128 lb
		SHEET 1 OF 1	