

REVISIONS				
REV.	DESCRIPTION	DATE	SHEET(S)	DRAWN BY
0	INITIAL RELEASE	8/26/2016	1	FES
1	CLEAN OUT WAS 1-1/2 NPT	12/19/2017	1	FES

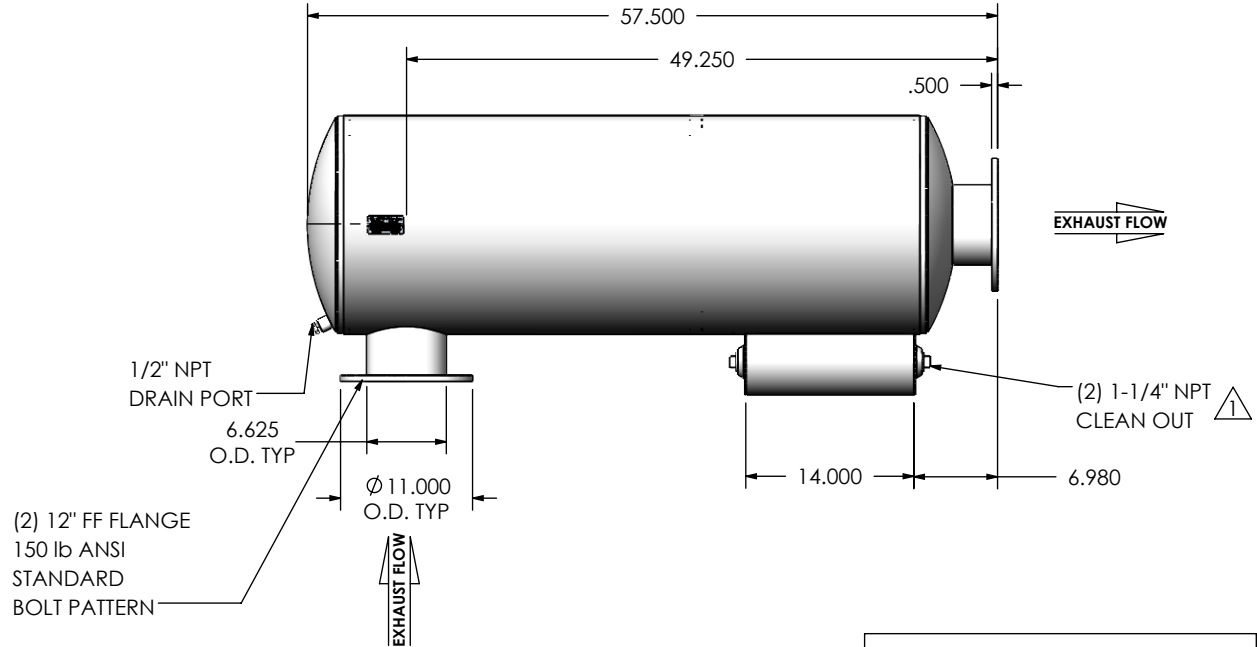
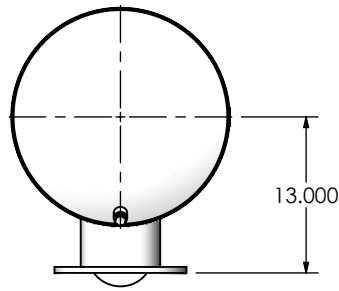
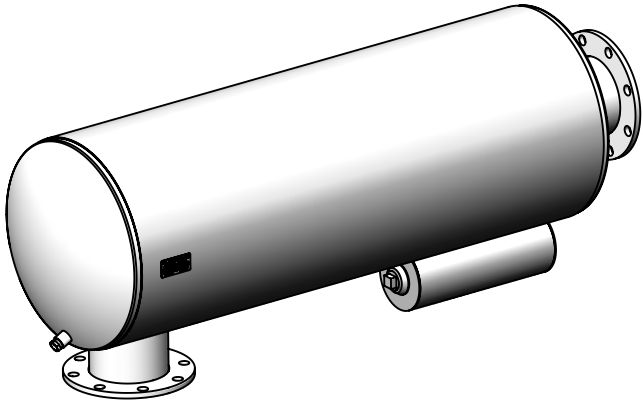

**NOTES:**

- DO NOT USE EQUIPMENT TO SUPPORT OTHER PARTS OF THE EXHAUST SYSTEM WITHOUT PROPER REINFORCEMENT

**MATERIAL CONSTRUCTION:**

- 304 STAINLESS STEEL

**PAINT:**

- HIGH TEMPERATURE BLACK (MIRATECH COATING SYSTEM 4)

PROJECT NAME	<p><b>PROPRIETARY AND CONFIDENTIAL</b></p> <p>THE INFORMATION CONTAINED IN THIS DRAWING IS THE SOLE PROPERTY OF MIRATECH GROUP, LLC. ANY REPRODUCTION IN PART OR AS A WHOLE WITHOUT THE WRITTEN PERMISSION OF MIRATECH GROUP, LLC IS PROHIBITED.</p>	<p>DIMENSIONS ARE IN INCHES UNLESS OTHERWISE SPECIFIED</p> <p>ANGLES: MACH: ±1° INCHES: ±0.125 BEND: ±3° MILLIMETERS: ±2</p>					
PROPOSAL NUMBER		DO NOT SCALE DRAWING		<p><b>SURGE0-06PF-3-000002D</b></p> <p><b>Sales Drawing</b></p>			
SALES ORDER NO.		DRAWN	DATE	DRAWING			
CUSTOMER P.O.		JFS	08/26/2016	SURGE0-06PF-3-000002D SD			
		REVIEWED BY	DATE	SIZE	SCALE 1:16	WEIGHT: 133 lb	SHEET 1 OF 1
			08/15/2016	A			