

20" FF FLANGE
150 lb ANSI
STANDARD
BOLT PATTERN
FLANGE FLOATS

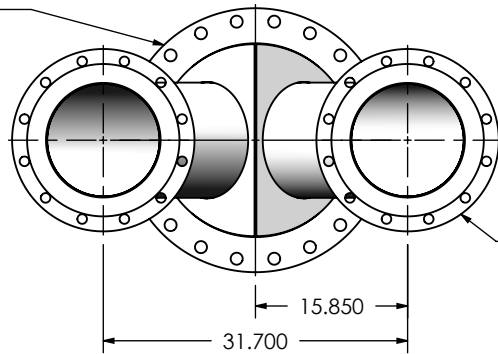

(2) 12" FF FLANGE
150lb ANSI
STANDARD
BOLT PATTERN
FLANGE FLOATS

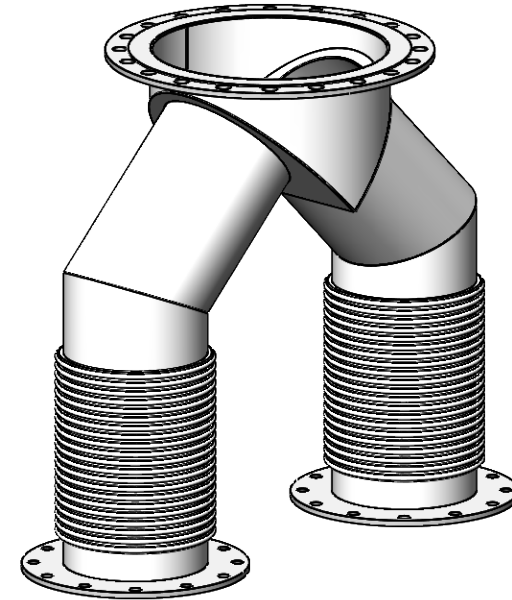

NOTES:

- DO NOT USE EQUIPMENT TO SUPPORT OTHER PARTS OF THE EXHAUST SYSTEM WITHOUT PROPER REINFORCEMENT

MATERIAL CONSTRUCTION:

- CARBON STEEL

PAINT:

- HIGH TEMPERATURE BLACK (MIRATECH COATING SYSTEM 5)

PROJECT NAME
PROPOSAL NUMBER
SALES ORDER NO.
CUSTOMER P.O.

PROPRIETARY AND CONFIDENTIAL

THE INFORMATION CONTAINED IN THIS DRAWING IS THE SOLE PROPERTY OF MIRATECH GROUP, LLC. ANY REPRODUCTION IN PART OR AS A WHOLE WITHOUT THE WRITTEN PERMISSION OF MIRATECH GROUP, LLC IS PROHIBITED.

DIMENSIONS ARE IN INCHES UNLESS OTHERWISE SPECIFIED

DIMENSIONAL TOLERANCES UNLESS OTHERWISE SPECIFIED	
ANGLES:	
MACH: ±1°	INCHES: ±0.125
BEND: ±3°	MILLIMETERS: ±2

DO NOT SCALE DRAWING

DRAWN	DATE
CLV	5/25/2017
REVIEWED BY	DATE
AJM	5/25/2017



Y12-D12TF2-20PF2-317-420-00-2
Sales Drawing

DRAWING	Y12-D12TF2-20PF2-317-420-00-2 SD	REV	0
SIZE	A	SCALE	1:20
WEIGHT	211 lb	SHEET	1 OF 1