

(2) 20" FF FLANGE
150 lb ANSI
STANDARD
BOLT PATTERN

[1270]
Ø 50"
NOM DIA

[32]
Ø 1 1/4"
TYP

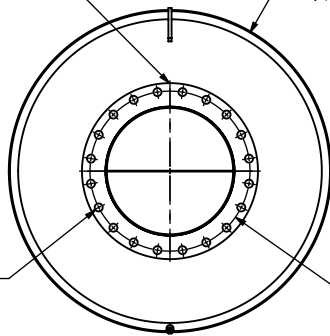

[635]
Ø 25"
BCD

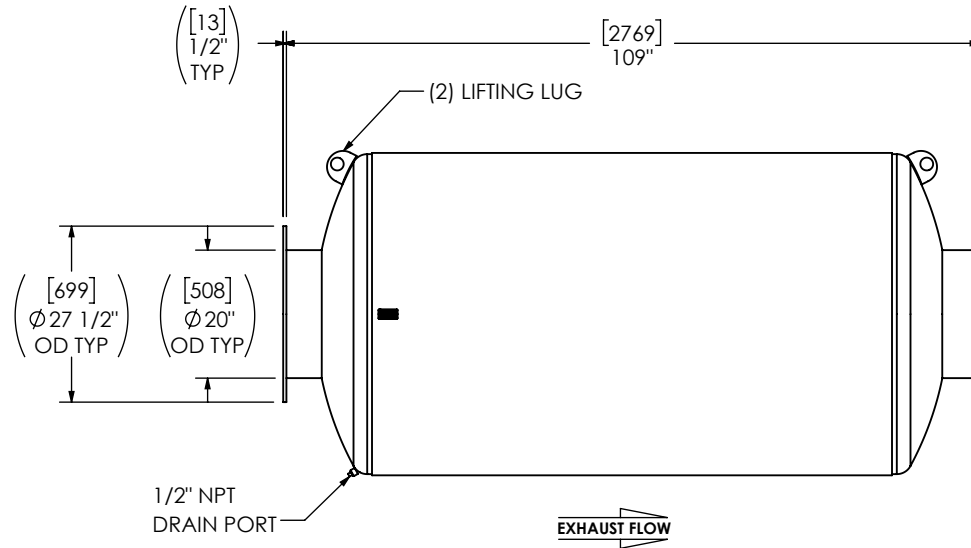

NOTES:

- DO NOT USE EQUIPMENT TO SUPPORT OTHER PARTS OF THE EXHAUST SYSTEM WITHOUT PROPER REINFORCEMENT

MATERIAL CONSTRUCTION:

- CARBON STEEL

PAINT:

- HIGH TEMPERATURE BLACK (MIRATECH COATING SYSTEM 5)

PROJECT NAME	<p>PROPRIETARY AND CONFIDENTIAL</p> <p>THE INFORMATION CONTAINED IN THIS DRAWING IS THE SOLE PROPERTY OF MIRATECH. ANY REPRODUCTION IN PART OR AS A WHOLE WITHOUT THE WRITTEN PERMISSION OF MIRATECH IS PROHIBITED.</p>	ALL DIMENSIONS IN INCHES (MILLIMETERS) UNLESS OTHERWISE SPECIFIED.																
PROPOSAL NUMBER		CRITICAL DIMENSIONS ARE CIRCLED																
SALES ORDER NO.		<table border="1"> <tr> <td colspan="2">TOLERANCES UNLESS OTHERWISE SPECIFIED</td> </tr> <tr> <td>< 12 [305]</td> <td>±1/8 [3]</td> </tr> <tr> <td>12 [305] ≥ 36 [915]</td> <td>±3/16 [5]</td> </tr> <tr> <td>36 [915] ≥ 360 [9150]</td> <td>±5/16 [9]</td> </tr> <tr> <td>> 360 [9150]</td> <td>±7/16 [12]</td> </tr> <tr> <td>ANGULAR</td> <td>±3°</td> </tr> <tr> <td>WEIGHT</td> <td>±10%</td> </tr> </table>	TOLERANCES UNLESS OTHERWISE SPECIFIED		< 12 [305]	±1/8 [3]	12 [305] ≥ 36 [915]	±3/16 [5]	36 [915] ≥ 360 [9150]	±5/16 [9]	> 360 [9150]	±7/16 [12]	ANGULAR	±3°	WEIGHT	±10%	<p>M2EE0-20PF-2-00000000</p> <p>SILENCER RESIDENTIAL GRADE M22</p>	
TOLERANCES UNLESS OTHERWISE SPECIFIED																		
< 12 [305]	±1/8 [3]																	
12 [305] ≥ 36 [915]	±3/16 [5]																	
36 [915] ≥ 360 [9150]	±5/16 [9]																	
> 360 [9150]	±7/16 [12]																	
ANGULAR	±3°																	
WEIGHT	±10%																	
CUSTOMER P.O. [P.N.]	<p>PROJECTION</p>	<table border="1"> <tr> <td>DRAWN</td> <td>SK</td> <td>DATE</td> <td>2023-12-05</td> </tr> <tr> <td>REVIEWED</td> <td>CSF</td> <td>DATE</td> <td>2023-12-05</td> </tr> </table>	DRAWN	SK	DATE	2023-12-05	REVIEWED	CSF	DATE	2023-12-05	<p>SALES DRAWING</p> <p>M2EE0-20PF-2-00000000 SD</p>	<table border="1"> <tr> <td>OEM NO</td> <td>REV</td> </tr> <tr> <td></td> <td>0</td> </tr> </table>	OEM NO	REV		0		
DRAWN	SK	DATE	2023-12-05															
REVIEWED	CSF	DATE	2023-12-05															
OEM NO	REV																	
	0																	
		<table border="1"> <tr> <td>SIZE</td> <td>SCALE</td> <td>WEIGHT</td> <td>SHEET NO.</td> </tr> <tr> <td>A</td> <td>DO NOT SCALE</td> <td>1:30</td> <td>1 OF 1</td> </tr> </table>	SIZE	SCALE	WEIGHT	SHEET NO.	A	DO NOT SCALE	1:30	1 OF 1	<table border="1"> <tr> <td>WEIGHT</td> <td>1376lb/625kg</td> </tr> </table>	WEIGHT	1376lb/625kg					
SIZE	SCALE	WEIGHT	SHEET NO.															
A	DO NOT SCALE	1:30	1 OF 1															
WEIGHT	1376lb/625kg																	