

(2) 4" FF FLANGE  
150 lb ANSI  
STANDARD  
BOLT PATTERN

[457]  
Ø 18"  
NOM DIA

[19]  
Ø 3/4"  
TYP

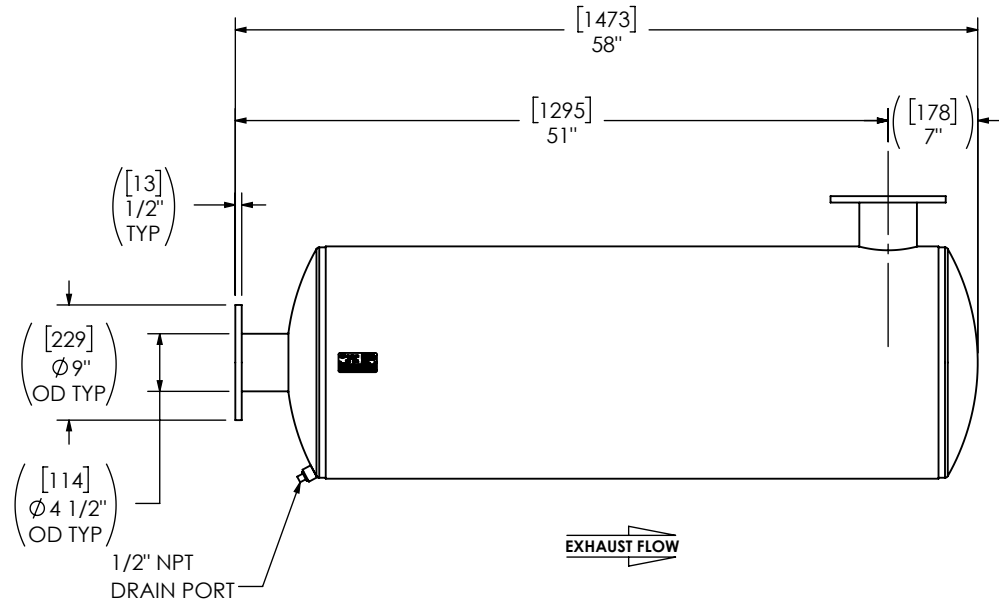
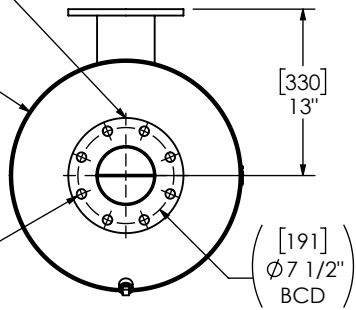

**NOTES:**

- DO NOT USE EQUIPMENT TO SUPPORT OTHER PARTS OF THE EXHAUST SYSTEM WITHOUT PROPER REINFORCEMENT

**MATERIAL CONSTRUCTION:**

- CARBON STEEL

**PAINT:**

- HIGH TEMPERATURE BLACK (MIRATECH COATING SYSTEM 5)

PROJECT NAME	<p><b>PROPRIETARY AND CONFIDENTIAL</b></p> <p>THE INFORMATION CONTAINED IN THIS DRAWING IS THE SOLE PROPERTY OF MIRATECH. ANY REPRODUCTION IN PART OR AS A WHOLE WITHOUT THE WRITTEN PERMISSION OF MIRATECH IS PROHIBITED.</p>	ALL DIMENSIONS IN INCHES (MILLIMETERS) UNLESS OTHERWISE SPECIFIED.																										
PROPOSAL NUMBER		CRITICAL DIMENSIONS ARE CIRCLED																										
SALES ORDER NO.		<table border="1"> <tr> <td colspan="2">TOLERANCES UNLESS OTHERWISE SPECIFIED</td> </tr> <tr> <td>&lt; 12 [305]</td> <td>±1/8 [3]</td> </tr> <tr> <td>12 [305] ≥ 36 [915]</td> <td>±3/16 [5]</td> </tr> <tr> <td>36 [915] ≥ 360 [9150]</td> <td>±5/16 [9]</td> </tr> <tr> <td>&gt; 360 [9150]</td> <td>±7/16 [12]</td> </tr> <tr> <td>ANGULAR</td> <td>±3°</td> </tr> <tr> <td>WEIGHT</td> <td>±10%</td> </tr> </table>	TOLERANCES UNLESS OTHERWISE SPECIFIED		< 12 [305]	±1/8 [3]	12 [305] ≥ 36 [915]	±3/16 [5]	36 [915] ≥ 360 [9150]	±5/16 [9]	> 360 [9150]	±7/16 [12]	ANGULAR	±3°	WEIGHT	±10%	<p><b>M6EA0-04PF-2-00001NIO</b></p> <p>SILENCER SUPER HOSPITAL GRADE M62</p>											
TOLERANCES UNLESS OTHERWISE SPECIFIED																												
< 12 [305]	±1/8 [3]																											
12 [305] ≥ 36 [915]	±3/16 [5]																											
36 [915] ≥ 360 [9150]	±5/16 [9]																											
> 360 [9150]	±7/16 [12]																											
ANGULAR	±3°																											
WEIGHT	±10%																											
CUSTOMER P.O. [P.N.]	<p>PROJECTION</p>	<table border="1"> <tr> <td>DRAWN</td> <td>SK</td> <td>DATE</td> <td>2024-01-18</td> </tr> <tr> <td>REVIEWED</td> <td>CSF</td> <td>DATE</td> <td>2024-01-18</td> </tr> </table>	DRAWN	SK	DATE	2024-01-18	REVIEWED	CSF	DATE	2024-01-18	<p>SALES DRAWING</p> <p>M6EA0-04PF-2-00001NIO SD</p> <table border="1"> <tr> <td>SIZE</td> <td>A</td> <td>SCALE</td> <td>DO NOT SCALE</td> <td>SCALE</td> <td>1:15</td> <td>WEIGHT</td> <td>142lb/64kg</td> </tr> </table>	SIZE	A	SCALE	DO NOT SCALE	SCALE	1:15	WEIGHT	142lb/64kg	<table border="1"> <tr> <td>OEM NO</td> <td>NO</td> <td>REV</td> <td>0</td> </tr> <tr> <td>SHEET NO.</td> <td colspan="3">1 OF 1</td> </tr> </table>	OEM NO	NO	REV	0	SHEET NO.	1 OF 1		
DRAWN	SK	DATE	2024-01-18																									
REVIEWED	CSF	DATE	2024-01-18																									
SIZE	A	SCALE	DO NOT SCALE	SCALE	1:15	WEIGHT	142lb/64kg																					
OEM NO	NO	REV	0																									
SHEET NO.	1 OF 1																											