

(2) 24" FF FLANGE  
150 lb ANSI  
STANDARD  
BOLT PATTERN

([35])  
Ø 1 3/8"  
TYP

([749])  
Ø 29 1/2"  
TYP

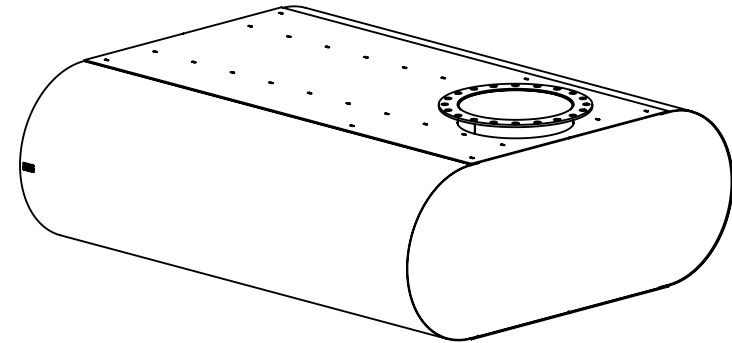
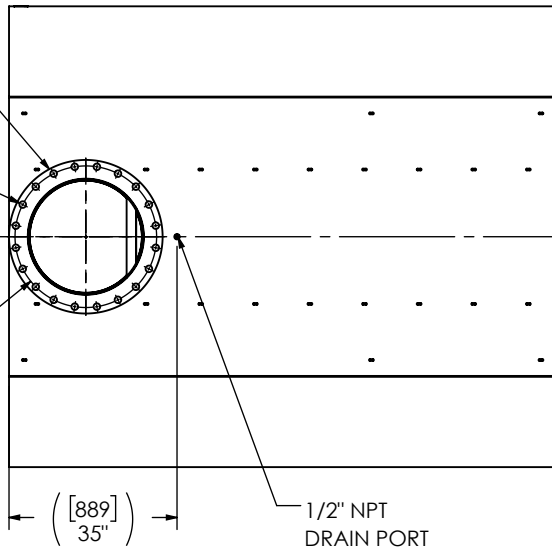

**NOTES:**

- DO NOT USE EQUIPMENT TO SUPPORT OTHER PARTS OF THE EXHAUST SYSTEM WITHOUT PROPER REINFORCEMENT

**MATERIAL OF CONSTRUCTION:**

- CARBON STEEL

**PAINT:**

- HIGH TEMPERATURE BLACK (MIRATECH COATING SYSTEM 5)

PROJECT NAME	<b>PROPRIETARY AND CONFIDENTIAL</b> THE INFORMATION CONTAINED IN THIS DRAWING IS THE SOLE PROPERTY OF MIRATECH. ANY REPRODUCTION IN PART OR AS A WHOLE WITHOUT THE WRITTEN PERMISSION OF MIRATECH IS PROHIBITED.	ALL DIMENSIONS IN INCHES (MILLIMETERS) UNLESS OTHERWISE SPECIFIED. CRITICAL DIMENSIONS ARE <b>CIRCLED</b>				
PROPOSAL NUMBER		TOLERANCES UNLESS OTHERWISE SPECIFIED < 12 [305] ±1/8 [3] 12 [305] ≥ 36 [915] ±3/16 [5] 36 [915] ≥ 360 [9150] ±5/16 [9] > 360 [9150] ±7/16 [12]				
SALES ORDER NO.		ANGLULAR WEIGHT ±3° ±10%	<b>MR5BT2-24PF-2-00003TVQ</b> SILENCER HOSPITAL GRADE MR42		OEM NO	REV 0
CUSTOMER P.O. [P.N.]		PROJECTION 	SALES DRAWING MR5BT2-24PF-2-00003TVQ SD		SHEET NO.	1 OF 1
		DRAWN SAG	DATE 2024-02-29	SCALE DO NOT SCALE	WEIGHT 4042lb/1837kg	
		REVIEWED CSF	DATE 2024-02-29	SIZE A		